

# PHARUS 1500 / PHARUS 1200

## PROFESSIONAL FOLLOW SPOTS



**PHARUS** is the latest evolution of the D.T.S. follow spots range.

PHARUS is a new follow spot ideal for all professional applications (theatres, concerts, television studios, fashion displays, special events, etc).

PHARUS offers a distinct improvement in projection quality – thanks to a new optical group with condenser lens.

PHARUS is available in two models: PHARUS 1500 (fitted with a 1500 W discharge lamp) and PHARUS 1200 (fitted with a 1200 W discharge lamp).

PHARUS offers also a series of updated functions that ensure effective and creative use.

- Luminosity: 28.000 Lux at 5 m (7°).
- New customizable colour changer with automatic switching system between colours (5 interchangeable gel filter holders);
- Linear iris-diaphragm (extractable);
- Linear zoom (7° to 16°);
- Linear focus;
- Mechanical dimmer with black-out.

PHARUS is designed to resist all the rigours of continuous use: the body is made in aluminium and stainless steel, which offer high resistance to heat and mechanical stress.

PHARUS is complete with external ballast (electromagnetic or electronic).



The Lighting Company



● PHARUS 1500 / PHARUS 1200 PROFESSIONAL FOLLOW SPOTS

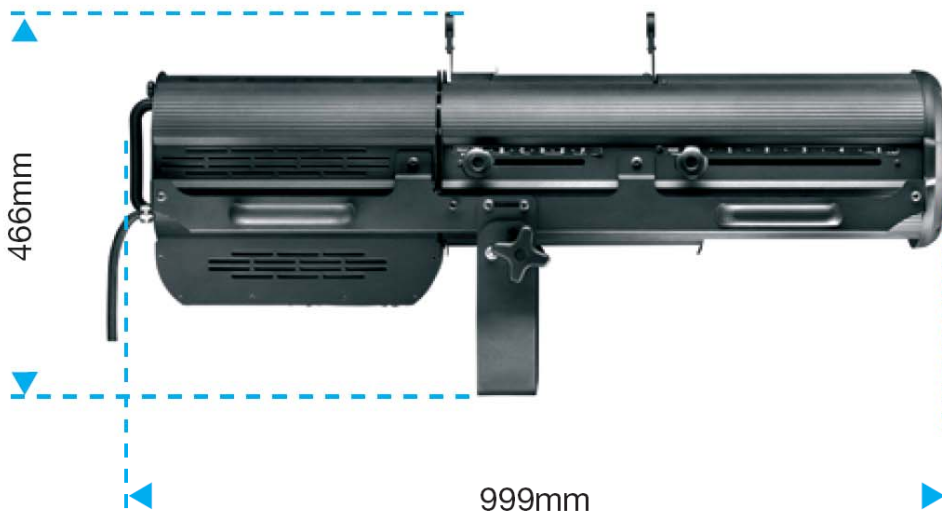
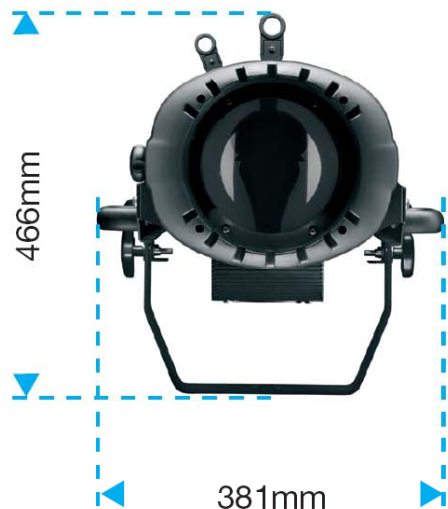

**Lamp**

Lamp: HTI 1500W/D7/60 (PHARUS 1500)

HMI 1200S (PHARUS 1200)

Base: SFc 10-4 with notch

**Optical group**

New optical group with condenser lens

Zoom 7° ÷ 16°

Linear focus

Extractable iris-diaphragm

Mechanical dimmer with black-out

**Colours**

Colour changer (optional): 5 interchangeable gel filter holders

Automatic switching system between colours

**Gobos**

Gobo holder for gobo projections (optional)

**Construction**

Made on aluminium and stainless steel

High resistance to heat and mechanical stress

Removable cover for easy access to lamp

**Safety**

Safety microswitches

**Power supply**

230V 50/60Hz

Power consumption 1600 VA, with built in power factor correction

External ballast (electromagnetic or electronic)

**Weight**

18,7 Kg (PHARUS);

14,5 Kg (ballast)



Optional Colour Changer

Preliminary information - D.T.S. reserves the right to make any functional or design modification to any of its products without any prior notice.



The Lighting Company