



Product Specification Sheet

Pacific 50° Fixed Beam



A base down axial profile delivering a “cool” beam of light in a range of fixed beams including 20°, 30°, 40° and 50°. The beam is of crisp “white” light with little or no distortion, ideal for pattern projection and precise beam shaping.

An energy efficient luminaire with active heat management system delivers longer life for filters, shutters and lower energy consumption.

Features

Produces more light than comparative traditional ellipsoidal profiles.

Cool ‘white’ light. Over 80% of the heat is removed from the light beam by the cold mirror and dissipated through the heat-sink.

Base down lamp mounted axially in the reflector to maximise light collection.

Choice of 600W, 800W, 1000W or 150W MH or MSR 575W lamp modules (each supplied with 1m mains cable).

Constructed from aluminium pressure die-castings and injection moulded Fortron plastic components.

Accurate and easy to use lamp peak/ flat adjustment.

Two pattern/ iris mounting positions.

Automatic disconnection of power on removal of lamp module.

Height adjustable yoke.

Lamps: 240V

GKV600W	15,000 lumens	300 hours average life
GLB600W	13,000 lumens	1500 hours average life
800W	22,000 lumens	400 hours average life
GAD1000WBP	25,000 lumens	250 hours average life
GAB1000W BP 230V	25,000 lumens	250 hours average life

Order Codes

18PACFB/6	Pacific Fixed Beam body, no lens, 600W, 800W
18PACFB/1	Pacific Fixed Beam body, no lens, 1000W
18PACL50	Pacific 50° lens assembly
19PACGHA	Pacific gobo holder, ‘A’ size
19PACCF	Additional colour frame
20IRIS	Pacific iris
19PACSMFB	Pacific lens safety mesh
20HC	Suspension hook clamp

Approvals

CE marked.



Photometric Data

Tests conducted using standard 240V production lamps manufactured by Philips.

		Beam Diameter									
Beam angle	50 °, m	0.0	3.7	7.5	11.2	14.9	18.7	22.4	26.1	29.8	
Throw Distance in m		0	4	8	12	16	20	24	28	32	
		Light Output in Lux									
Lamp											
240V BP 1000W	50°	Peak	1950	488	217	-	-	-	-	-	-
		Flat	1550	388	172	-	-	-	-	-	-
240V 800W	50°	Peak	2950	738	328	-	-	-	-	-	-
		Flat	1400	350	156	-	-	-	-	-	-
240V GKV 600W	50°	Peak	2070	518	230	-	-	-	-	-	-
		Flat	1050	263	117	-	-	-	-	-	-
80V 1200W	50°	Peak	4200	1050	467	263	-	-	-	-	-
		Flat	2350	588	261	147	-	-	-	-	-
MSR 575 / 2	50°	Peak	5300	1325	589	331	-	-	-	-	-
		Flat	3000	750	333	188	-	-	-	-	-
CDM-T 942 / 830 150W	50°	Peak	1620	405	180	-	-	-	-	-	-
		Flat	1150	288	128	-	-	-	-	-	-
CDM-T 942 / 830 70W	50°	Peak	1000	250	-	-	-	-	-	-	-
		Flat	550	138	-	-	-	-	-	-	-
CST 250 HR	50°	Peak	1862	466	207	116	-	-	-	-	-
		Flat	1330	333	148	-	-	-	-	-	-

Physical Data

Weight: 8.1kg

Carton size: 650mm x 400mm x 260mm (estimated)

Colour frame size: 158mm square

Gobo size: A, 75mm diameter image

Included: 1x colour frame, 1x fitted safety bond, 1x heat sink guard, 1x M12 suspension bolt set and instruction leaflet.

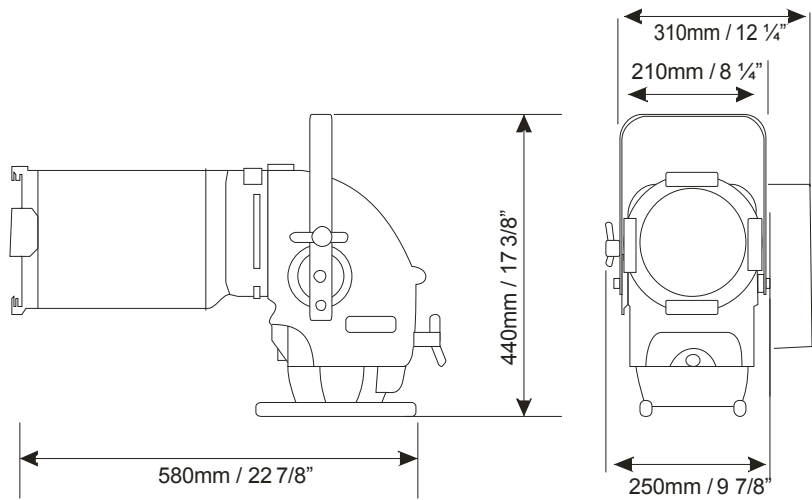

Selecon reserves the right to change the specifications without notice (07/08).