

# *Installation Manual*

Please scroll down for Instructions

## 1 INTRODUCTION

Six Track items are manufactured from a variety of interchangeable parts to provide an efficient tracking system.

This handbook describes each item and some applications.

## 2 TRACK and SUPPORT BRACKETS

Separate sections are bolted together to form a complete system and the system is supported by a series of brackets. The maximum length is 10 metres for single track and 18 metres overall for overlapping tracks. The maximum distance between support brackets is 2.25m. for 'cloth open' and 1.6m. for 'cloth bunched'.

Track items :

Part No.	Description	Weight
T63705	0.25 metre straight.	0.63 kg.
T63706	0.5 metre straight.	1.19 kg.
T63707	0.75 metre straight.	1.65 kg.
T63708	1.0 metre straight.	2.24 kg.
T63710	2.0 metre straight.	4.47 kg.
T63715	3.0 metre straight.	6.71 kg.
T63730	90° curve @ 0.5 metre radius.	1.96 kg.
T63731	90° curve @ 0.75 metre radius.	2.73 kg.
T63732	90° curve @ 1.0 metre radius.	3.62 kg.
T63733	90° curve @ 0.6 metre radius.	2.17 kg.
T63734	90° curve @ 0.9 metre radius.	3.50 kg.
T63735	45° curve @ 0.5 metre radius.	1.00 kg.
T63736	45° curve @ 0.75 metre radius.	1.40 kg.
T63737	45° curve @ 1.0 metre radius.	1.82 kg.
T63738	90° curve @ 2.0 metre radius (2 Sections).	7.20 kg.
T63739	90° curve @ 3.0 metre radius (3 Sections).	10.80 kg.
T63749	Top Rail Clamp (29mm U bolt).	0.07 kg.
T63750	Adjustable Support Bracket (includes U bolt).	0.25 kg.
T63751	Short Support Bracket (includes U bolt).	0.15 kg.
T63752	Overlap Bracket (includes two U bolts).	0.31 kg.
T63753	Barrel Bracket.	0.57 kg.
T63754	Parallel Bracket (150mm centres).	0.40 kg.
T63765	Bolt on End Plate.	0.20 kg.
T63795	Boxes of 100 ; M5 x 16 pozi screws, nuts and spring washers.	

### **3 RUNNERS AND END STOPS**

For 'Walk along' systems, the curtain is pulled along by a person, usually from floor level. Such a system requires runners and two end stops for each run of track. Twin Hooks are used to attach the curtain to the Runners.

Recommended runner spacing is 300mm for 'cloth open'. The 'bunched length' is 35mm per runner. Maximum load per runner is 6 kg.

The fixed end of the curtain should be attached to one End Stop while another End Stop controls the 'closed' position. End Stops are adjustable and can be re-positioned for fine tuning after the installation is completed.

For 'Line operated' systems, the hauling line attaches to a Master Runner supporting the leading edge of each curtain. A number of guide pulleys attach to the tracking to ensure correct operation from manual or mechanical operation of the hauling line.

Runners, twin hooks and end stops :

Part No.	Description	Weight
T63755	Master Runner.	0.16 kg
T63756	Ball Raced Runner.	0.03 kg.
T63760	End Stop.	0.13 kg.
T63796	Nylon Twin Hook	

#### **4 HAULING LINE AND GUIDANCE**

Pulleys and guides are attached to the tracking to ensure correct action. At one end of the track there is a Return Pulley to pass the line back alongside the tracking.

At the other end there is a twin head pulley to take the line down to the operator at floor level, but this is omitted where there is an electric track drive fitted to one end of the track. Pulleys, line and guides :

Part No.	Description	Weight
T63770	Line Support.	0.52 kg.
T63775	Return Pulley.	0.25 kg.
T63776	Twin Head Pulley.	0.60 kg.
T63777	Single Guide Pulley.	0.13 kg.
T63778	Double Guide Pulley.	0.11 kg.
T63780	Black Hauling Line.	
T63785	Swing arm boom.	0.28 kg.
T63798	Head Pulley.	0.27 kg.
T63799	Head Guide Pulley *.	0.22 kg.

\*For use with head pulley, (but inside end frame) when the track ends with a curve.  
(see figs 10, 14 and 15)

## **5 OPERATION OF HAULING LINE**

Hauling line may be manually operated hand over hand, or by means of a track drive unit, manual or electrical. For manual operation the line passes down to a Weighted Pulley to maintain tension. The Weighted Pulley features a generous eye to enable loading to be increase by lanyard or extra weights. The Weight Pulley may be free hanging or floor fixed for increased control. Line operation devices are :

Part No.	Description
T63820	Weighted Pulley.
T63825	Floor Fixing Handline Pulley.
T63840	Track Drive - Hand Operated - Wall Mounted.
T63841	Track Drive - Hand Operated - Floor Mounted.
T63845	Track Drive - Electric - Track Mounted.
T6384503*	Track Drive - Electric - Track Mounted.
T63846	Track Drive - Electric – Wall or Floor Mounted.
T6384603*	Track Drive - Electric – Wall or Floor Mounted.
T63850	Track drive optional remote control c/w emergency stop.

\* - 03 version is three phase fixed speed.

## **6 LAYOUT**

Popular layouts are straight tracks with single wipe or having one metre overlap.

Complex layouts include curves. Special features can be supplied to order.

**7 SELECTION OF TRACK INSTALLATION COMPONENTS**

(By selection of suitable kit from the following))

***WALKALONG TRACK***

T63880	WALKALONG STARTER TRACK KIT - 2M STRAIGHT
T63881	WALKALONG OVERLAP KIT (1M OVERLAP)
T63888	WALKALONG TRACK KIT - 1 METRE EXTENSION
T63892	WALKALONG TRACK KIT - 2 METRE EXTENSION
T63896	WALKALONG TRACK KIT - 3 METRE EXTENSION
T63897	WALKALONG TRACK KIT - CURVE 0.5M RADIUS CURVE
T63898	WALKALONG TRACK KIT - CURVE 0.75M RADIUS CURVE
T63899	WALKALONG TRACK KIT - CURVE 1M RADIUS CURVE

***LINE OPERATED TRACK***

T63901	LINE OPERATED STARTER TRACK KIT - 2 METRE STRAIGHT
T63902	LINE OPERATED OVERLAP KIT - 1 METRE OVERLAP
T63906	LINE OPERATED TRACK KIT - 1 METRE EXTENSION
T63910	LINE OPERATED TRACK KIT - 2 METRE EXTENSION
T63914	LINE OPERATED TRACK KIT - 3 METRE EXTENSION
T63915	LINE OPERATED TRACK KIT - CURVE 0.5M RADIUS CURVE
T63916	LINE OPERATED TRACK KIT - CURVE 0.75M RADIUS CURVE
T63917	LINE OPERATED TRACK KIT - CURVE 1M RADIUS CURVE

***OVERLAP TRACK KITS***

T63920	4M OVERLAP TRACK KIT
T63921	5M OVERLAP TRACK KIT
T63922	6M OVERLAP TRACK KIT
T63923	7M OVERLAP TRACK KIT
T63924	8M OVERLAP TRACK KIT
T63925	9M OVERLAP TRACK KIT
T63926	10M OVERLAP TRACK KIT
T63927	11M OVERLAP TRACK KIT
T63928	12M OVERLAP TRACK KIT
T63929	13M OVERLAP TRACK KIT
T63930	14M OVERLAP TRACK KIT
T63931	15M OVERLAP TRACK KIT

## 8 SELECTION OF TRACK INSTALLATION COMPONENTS

(By individual component selection)

### 8.1 General.

Compile a layout diagram to include all details. Figures 1 and 2 are examples of layout diagrams.

The spacing of supports shown in the examples assume that this is suitable for the venue, however the spacing can be varied throughout to suit convenient mounting points in the building concerned, provided the maximum ratings in section 2 are not exceeded. Maximum recommended span between supports is 2.25m (cloth open) and 1.6m (cloth bunched).

### 8.2 List Track.

Compile a list of track lengths according to the layout diagram.

If the track length has to be accurate to less than half a metre, there are two options:-

a) Each length of track comprises a series of frames, each frame being welded **one side only** to a support tube at the top and also to the two running rails. Track may be shortened by cutting carefully by hack saw beside any frame **on the side with no welds**. Frames are spaced at 33 cm. so that this will give the required length to within 17 cm.

b) Any length of track may be shortened to the exact length required by cutting between frames, and fitting a 'Bolt on End Plate' (T63765). However this feature has to be situated at the end of the tracking assembly as it is a 'true' end plate and runners cannot pass through it.

### 8.3 List Support Brackets.

Compile a list of support brackets, overlap brackets, wall brackets, girder clamps etc. according to the layout diagram. See fig. 3 for installation dimensions. See main Doughty catalogue for wall brackets etc.

#### 8.4 List Runners and End Stops.

List the number of runners required from the layout diagram. If the installation is for 'walk along' operation, then a separate end stop will be necessary at each end of each track. E.g. for fig. 2, four end stops are required. If installation is to be line operated, then please refer to section 8.

#### 8.5 Electric operation.

For electric operation it is essential to allow an additional 0.3 m of length per track to allow for overrun at limit switches.

### **9 SELECT LINE OPERATION ACCESSORIES**

#### 9.1 General.

Compile a layout diagram to show the hauling line routing. Figures 4 and 5 are examples of layout diagrams for hauling lines. It is assumed that the track is 5 metres above floor level and the hauling line will be manually operated from floor level. (See sections 9.5 and 10.1 for electrical operation.)

#### 9.2 Basic List for Single wipe as shown in fig. 4.

The diagram demonstrates a requirement for :

One	T63755	Master Runner
One	T63775	Return Pulley
One	T63776	Twin Head Pulley
Three	T63770	Line Supports
Three	T63777	Single Guide Pulleys
36 m.*	T63780	Hauling Line

\*(Includes 10% extra for cutting to length during installation)

The single guide pulleys and the line supports should be positioned at approximately 2.5m. centres to prevent excessive sagging of the line between the ends of the tracking.

### 9.3 Basic List for use with overlapped track as shown in fig. 5.

The diagram demonstrates a requirement for :

Two	T63755	Master Runners
One	T63775	Return Pulley
One	T63776	Twin Head Pulley
Two	T63770	Line Supports
Two	T63777	Single Guide Pulleys
Two	T63778	Double Guide Pulleys
36 m*	T63780	Hauling Line

\*(Includes 10% extra for cutting to length during installation)

The single guide pulleys and the line supports should be positioned at approximately 2.5m. centres to prevent excessive sagging of the line between the ends of the tracking.

## **10 SELECTION OF METHOD FOR OPERATING HAULING LINE**

### 10.1 General.

The simplest method is to provide a weighted pulley with the line length arranged so that the weighted pulley is just above floor level. The line runs from one of the twin head pulleys, down to the weighted pulley and then up to the other head pulley. Pulling down on one part of the line closes the curtain while the other part is for opening. This can be refined by use of a floor fixing handline pulley to avoid the swinging of the weighted pulley.

Alternatively, mechanical capstan track drives can be used, either with hand crank or electrically operated. Electric drives are normally mounted to one end of the track. This enables the curtain tracking to be flown as for conventional house curtains for any theatre having a fly tower.

### 10.2 Handline Weighted Pulley.

Select the following :

One	T63820	Handline Weighted Pulley
-----	--------	--------------------------

10.3 Floor Fixing Handline Pulley.

Alternatively select the following :

One            T63825            Floor Fixing Handline Pulley

10.4 Hand Crank Operation.

For easy smooth operation without the requirement for hauling hand over hand, select either :

                  One            T63840            Hand operated track drive for wall mounting.  
**OR**            One            T63841            Hand operated track drive for floor mounting.

10.5 Electric Operation.

For remote electric operation from 240 volts 50 cycles single phase supply, select either :

                  One            T63845            Electric track drive, track mounted.  
**OR**            One            T63846            Electric track drive, floor or wall mounted.

## **11 TRACK INSTALLATION**

### 11.1 General.

#### **SAFETY WARNING**

**The track will be installed at a height such that any failure would be hazardous. Installation must be undertaken under the supervision of a competent person. All suspension points must be assessed to ensure that load carrying capabilities are adequate, and such assessment has to be recorded and retained by the installer who shall also provide a copy to the person responsible for the venue.**

Refer to fig. 1 or 2 as appropriate, and assess the maximum weight of curtain that may be used. Plan the anchorages to enable supporting of the track as described in section 7. When anchorages are less than ideally situated it may be necessary to provide spreader beams to support the track correctly.

Calculate the total load for each track support point allowing for the weight of all the track and accessories; as well as the curtain whether open or bunched or part bunched as during opening. Also allow for the loading due to line operation where the loading at the twin head pulley may be increased by up to 50 kg by the effect of hauling on the line.

For each anchorage allow for the weight of curtain plus all the track components and the weight of items connecting the track to the anchorage.

For a track mounted electric track drive the mounting details and weight are listed within a separate handbook, entitled 'Electric Track Drive for Six Track' and available from Doughty.

### 11.2 Procedure.

1. Install all support brackets and adjust to correct level.
2. Install each length of track separately without joining together.
3. Carefully adjust the position of each length so that the ends are correctly aligned.
4. Secure each track joint using four screws with nuts and spring washers applied to the two highest and two lowest holes in the track end frames. Run each nut to the washer, but leave hand tight.
5. Tighten each joint in turn, taking care to ensure alignment of the top and inner surfaces of both rails. This may be achieved using a  $\varnothing$  5mm. steel rod in adjacent holes to move the joint face alignment before finally tightening the screws.
6. Check that the track is level and that all the joints are free from any step, re-aligning where necessary.
7. Double check all fasteners are properly secure.

## **12 ACCESSORY INSTALLATION**

### 12.1 General.

All accessories are to be installed as planned in accordance with the foregoing. This section highlights a few guidance notes for specific items.

### 12.2 Master Runner T63755.

Insert Master Runners as required from an open end of the tracking and position as shown in figs. 4 & 5. It is advisable to do this before fitting end pulleys.

### 12.3 Twin Head Pulley T63776.

The Twin Head Pulley is made from two Head Pulleys (T63798) bolted together and stabilised by a brace, supplied assembled as shown at the left of fig. 6. This is handed for use as shown in fig. 5. The assembly can be taken apart and re-assembled opposite handed as shown at the right of fig. 6. Head pulleys may be used singly to divert lines to facilitate a convenient operating position if necessary.

Refer to fig. 7 for correct fitting of Twin Head Pulley to end of track.

#### 12.4 Return Pulley T63775.

The Return Pulley is required at the end of the track remote from the Twin Head Pulley, positioned as shown in figs. 4 & 5. The line fitted to the Master Runner will be offset from the centre line of the track, either on the left or on the right, as shown in fig. 8. Refer to fig. 7 for correct fitting of the Return Pulley to the end of track as this must be compatible with the line attached to the Master Runner when it reaches this end of the track.

#### 12.5 Double Guide Pulley T63778.

The Double Guide Pulley is required at the end of each track, positioned as shown in fig. 5 where there is an overlap. The line is fitted to the Master Runner, either on the left or on the right, as shown in fig. 8. Refer to fig. 7 for correct fitting of double guide pulley to each end of track at an overlap.

#### 12.6 Single Guide Pulley T63777.

The Single Guide Pulley is required to prevent excessive sagging of the return line between the ends of the tracking and should be positioned at approximately 2.5m. spacing as shown in figs. 4 & 5. Refer to fig. 7 for correct fitting of single guide pulley to the side of track.

(Note : The double guide pulley can also be mounted vertically to provide the same function instead of using a single guide pulley.)

#### 12.7 Line Support T63770.

The Line Support is required to prevent excessive sagging of the hauling line between the ends of the tracking and the master runner, but it also retracts to allow the master runner to pass by. Line Supports should be positioned at approximately 2.5m. spacing as shown in figs. 4 & 5. Refer to fig. 9 for correct fitting of the Line Support to the support tube of the track.

#### 12.8 Hauling Line T63780.

Proceed with installation as follows.

1. With all the pulleys in place as in figs. 4 to 7, place in position the track drive or weighted pulley or floor pulley which is described in section 9.

2. Start at a Master Runner and thread the line around the complete system (past the other Master Runner if there is an overlap) to end up back at the original Master Runner
3. If there is an overlap, adjust to establish the required length. Cut back but still leave the line about 30cm long and tie a reef knot alongside that Master Runner. Attach line to the other Master Runner as shown at the top of fig. 8.
4. Cut the ends of the line to the final required length and heat-seal square and tidy. Secure the two cut ends at the Master Runner as shown at the bottom of fig. 8.

## **13 INSTALLATIONS INCLUDING CURVES**

### **13.1 General.**

Three standard 90° curves are available, T63730 for 0.5 metre radius, T63731 for 0.75 metre radius and T63732 for 1.0 metre radius.

These curves are designed so that they can be cut carefully by hacksaw beside any frame **on the side with no welds** to provide less angle if required.

Other curves can be provided to special order.

### **13.2 Layout.**

Compile a layout diagram using the same principles as described for straight tracks in section 7. At least one support is recommended to be attached to each curve.

Figure 10 is an example of a layout diagram with curves.

### **13.3 Pulleys for curves.**

Attach one double guide pulley to each frame towards the inside of the curve as shown by fig. 11.

### **13.4 Cross-over facility.**

Use two single guide pulleys to divert the return line to the other side of the track to improve 'path of line' layout, as shown by fig. 12.

### 13.5 Pulley layout for 'S' layout.

For the 'S' layout it is necessary to take the return line around the outside of one of the curves. This is achieved using 'Return Pulleys' mounted to the outside of every other frame as shown by fig. 13.

### 13.6 Twin Head Pulley on end of Curve.

For the Twin Head Pulley to be mounted at the end of a curve, a Head Guide Pulley is required as shown by figs. 10, 14 & 15.

## **14 SPECIAL FEATURES**

There are many special features that can be provided for tracking and such items may be available to special order. Please discuss requirements with Doughty.

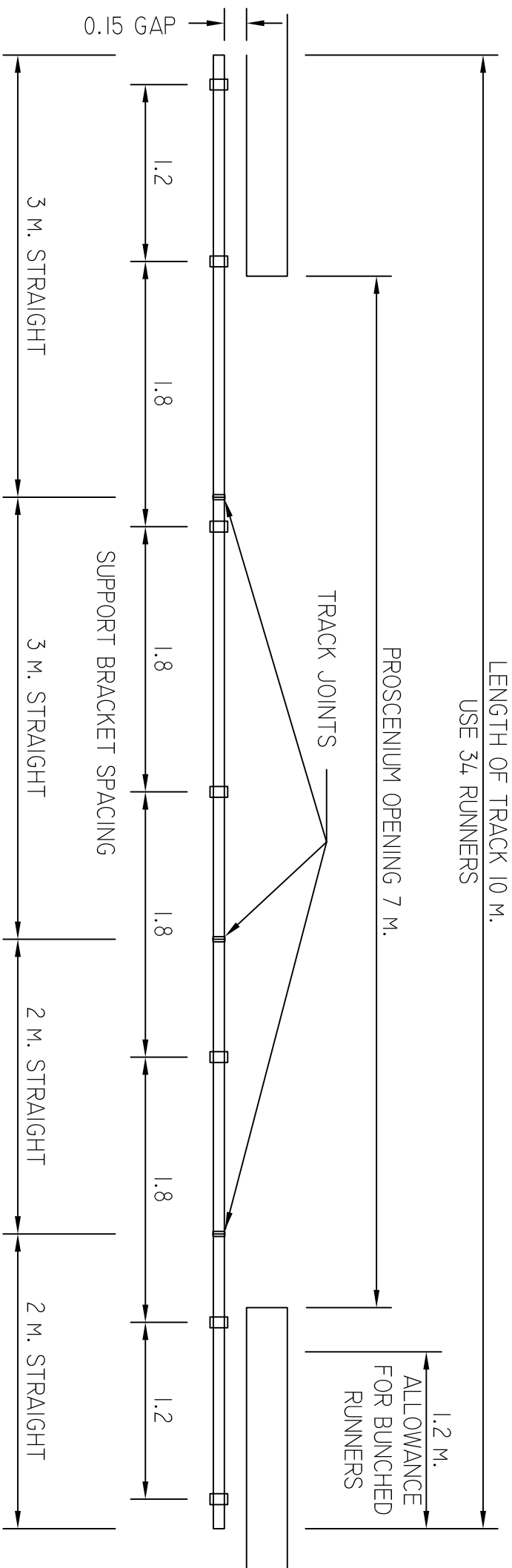

FIG. 1 ~ LAYOUT DIAGRAM FOR SINGLE WIPE ~ PLAN VIEW.

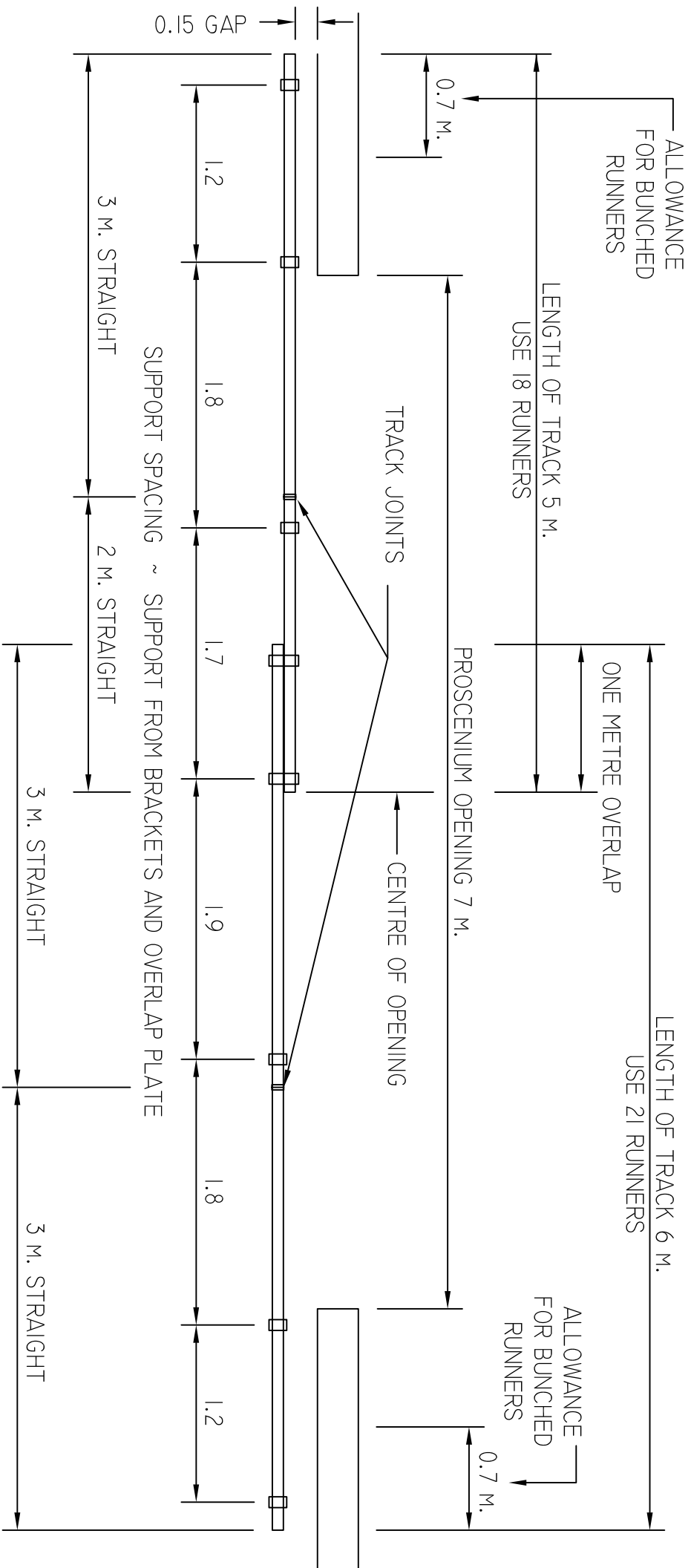
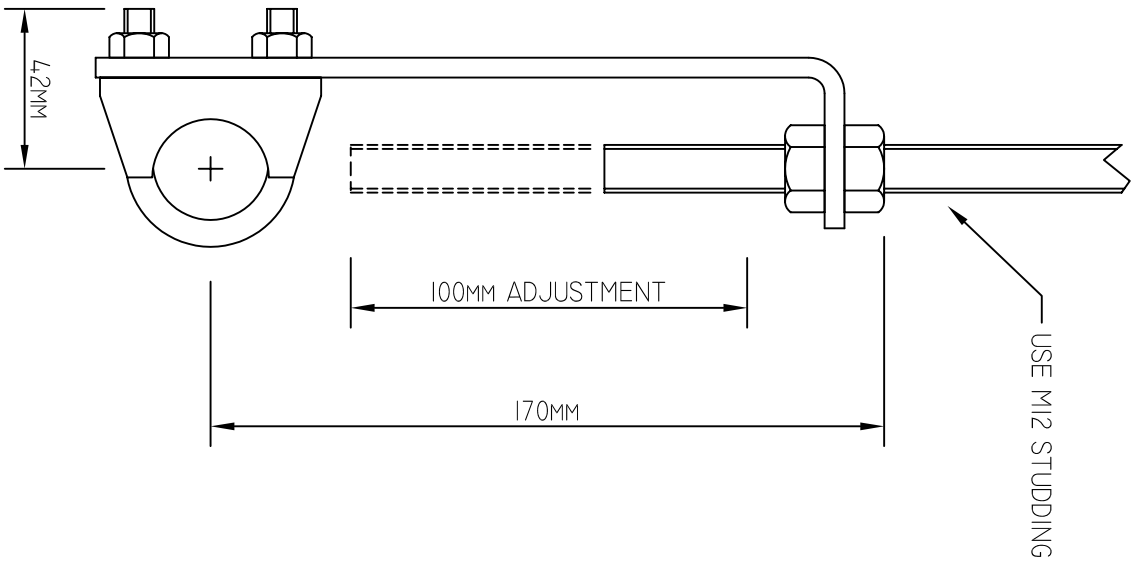

FIG. 2 ~ LAYOUT DIAGRAM WITH OVERLAP ~ PLAN VIEW.

ADJUSTABLE SUPPORT BRACKET

T63850



USE M12 STUDDING

SHORT SUPPORT BRACKET

T63851

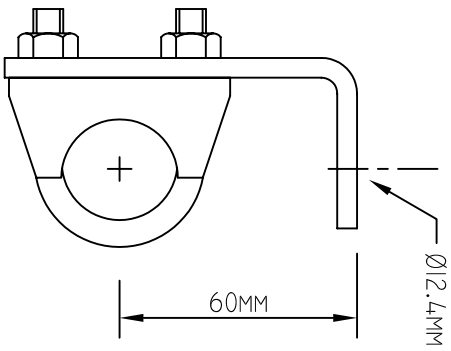

OVERLAP BRACKET

T63752

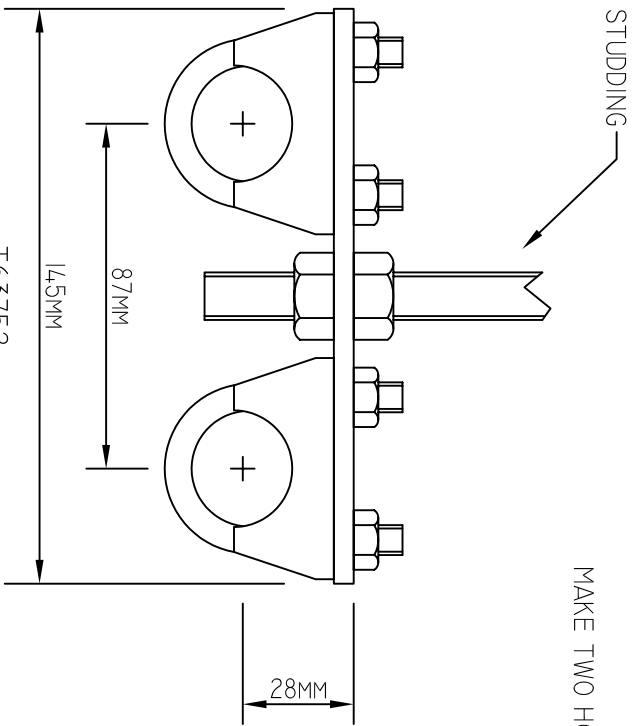

MAKE TWO HOLES Ø9mm @ 36mm CRS.

TRACK PROFILE

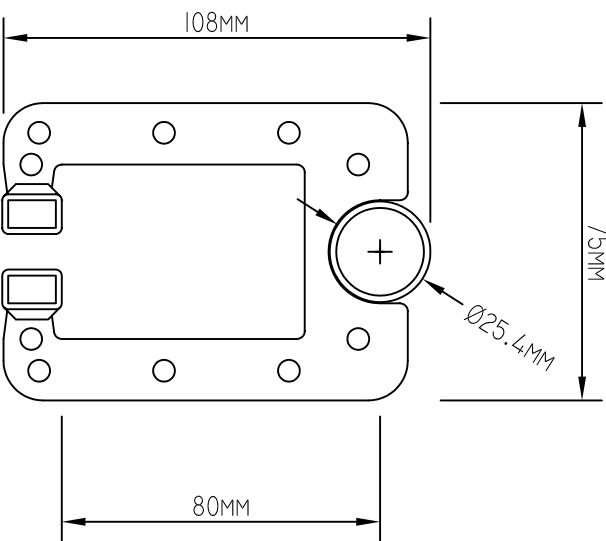

T63749  
TOP RAIL CLAMP

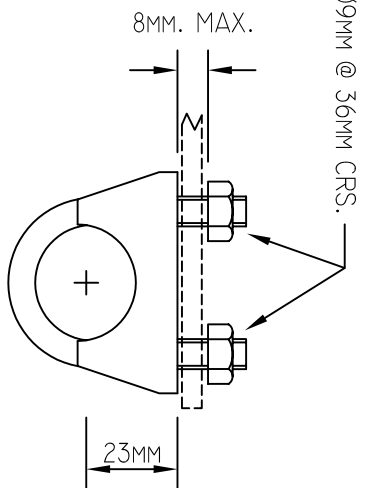

FIG 3 INSTALLATION DIMENSIONS

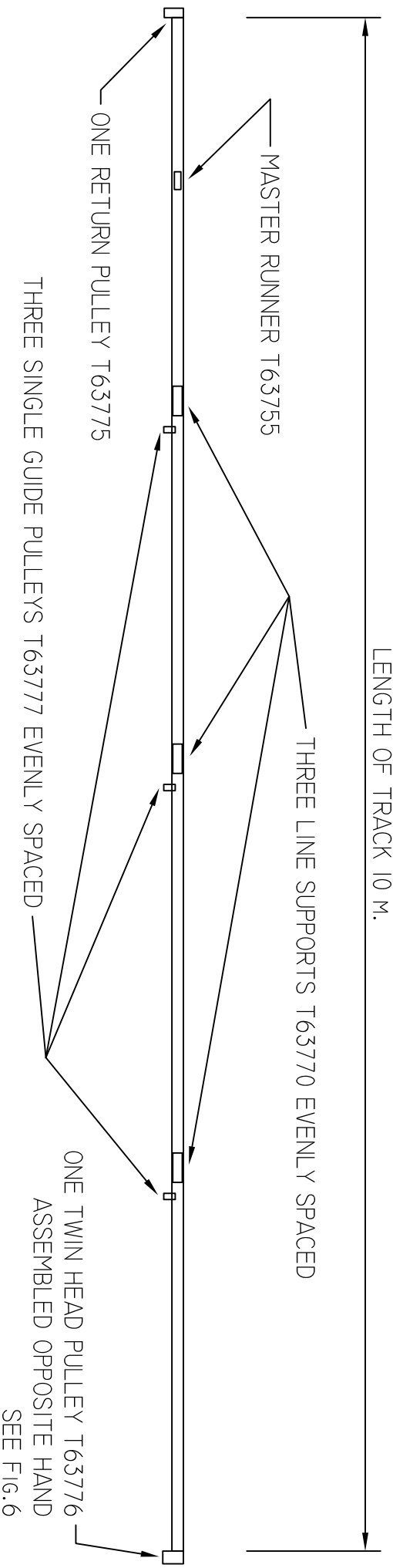

FIG. 4 ~ LAYOUT DIAGRAM FOR SINGLE WIPE LINE OPERATION ~ PLAN VIEW.

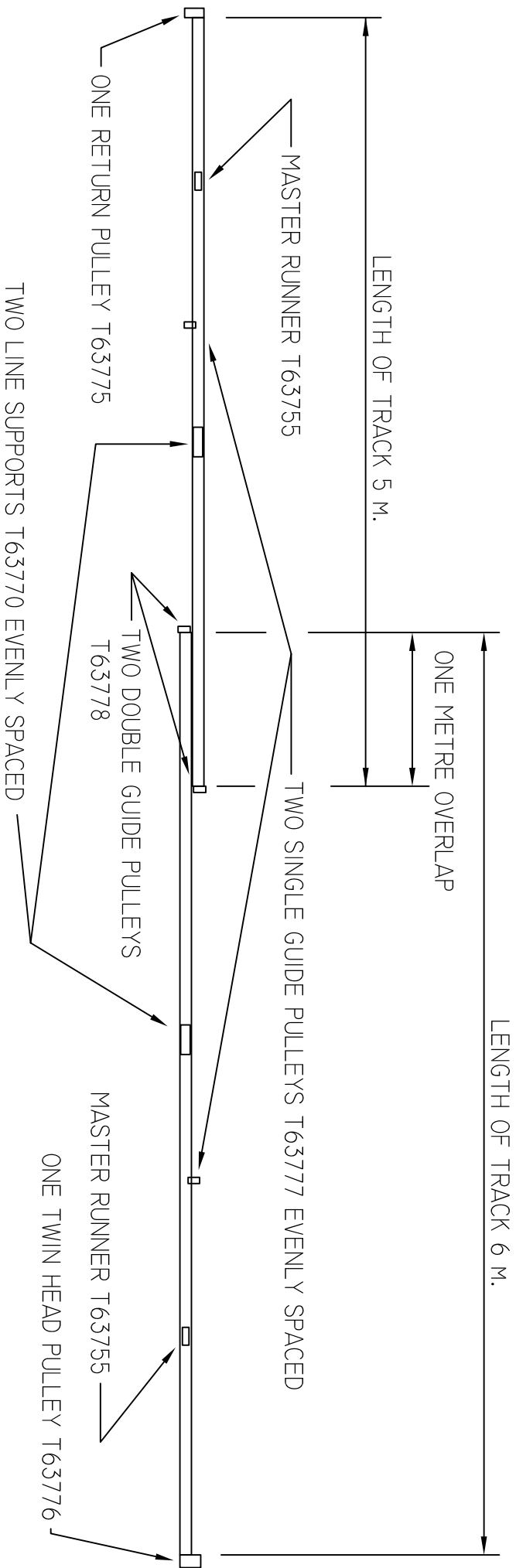
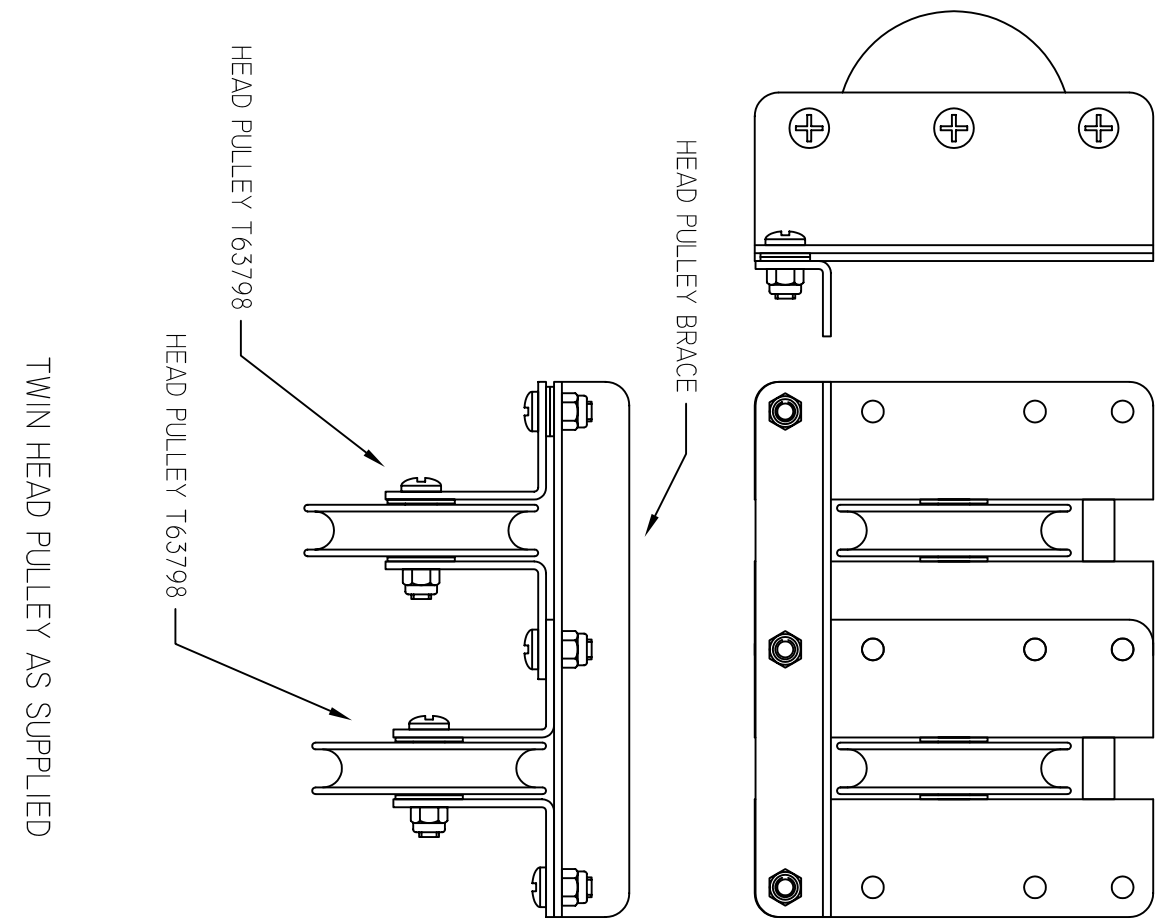

FIG. 5 ~ LAYOUT DIAGRAM FOR LINE OPERATION WITH OVERLAP ~ PLAN VIEW.



TWIN HEAD PULLEY AS SUPPLIED

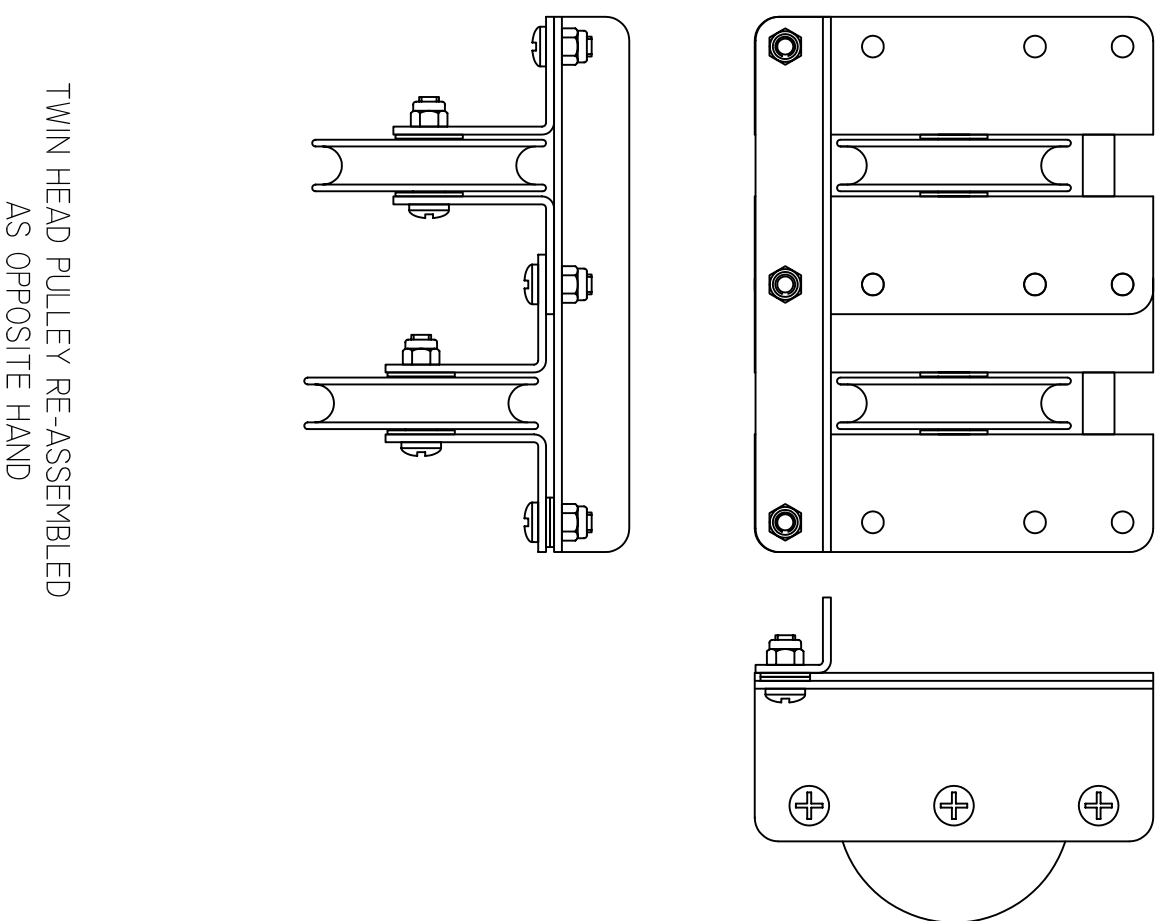
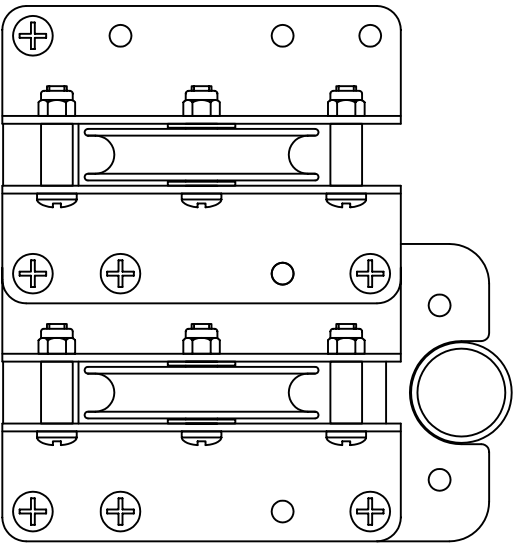
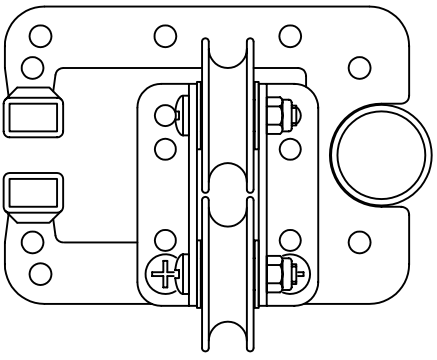

FIG. 6 ~ TWIN HEAD PULLEY T63776



TWIN HEAD PULLEY FITTED TO END OF TRACK



DOUBLE GUIDE PULLEY  
FITTED TO END OF TRACK  
FOR LINE TO RIGHT  
OF MASTER RUNNER

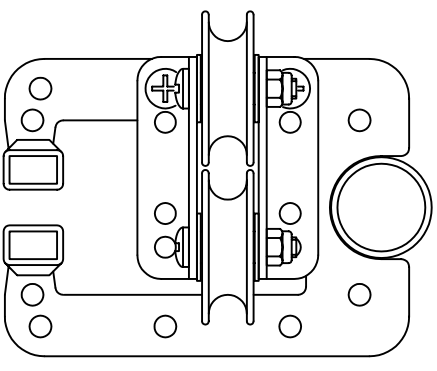

DOUBLE GUIDE PULLEY  
FITTED TO END OF TRACK  
FOR LINE TO LEFT  
OF MASTER RUNNER

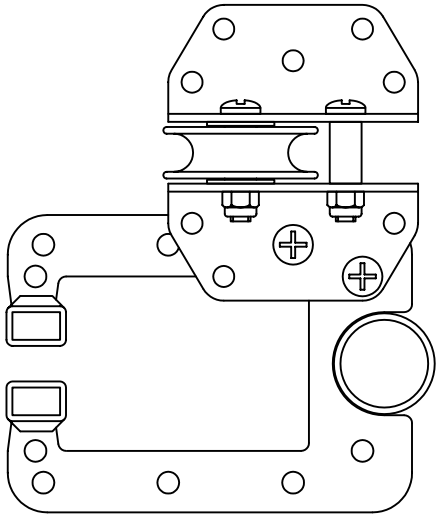

SINGLE GUIDE PULLEY  
FITTED TO SIDE OF TRACK  
FOR RETURN LINE TO LEFT  
OF TRACK

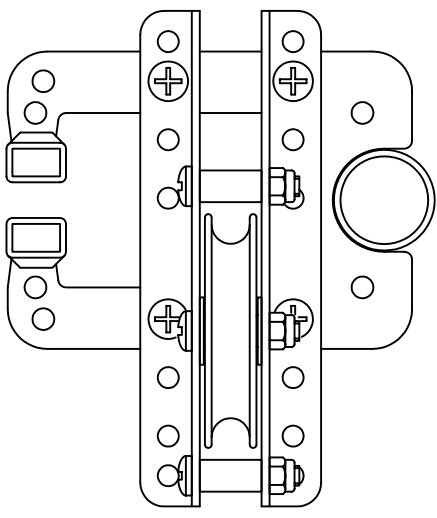

RETURN PULLEY  
FITTED TO END OF TRACK  
FOR LINE TO RIGHT  
OF MASTER RUNNER

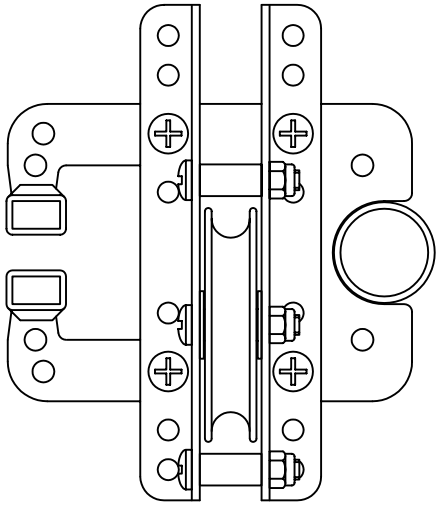

RETURN PULLEY  
FITTED TO END OF TRACK  
FOR LINE TO LEFT  
OF MASTER RUNNER

FIG. 7 ~ PULLEYS FITTED TO TRACK

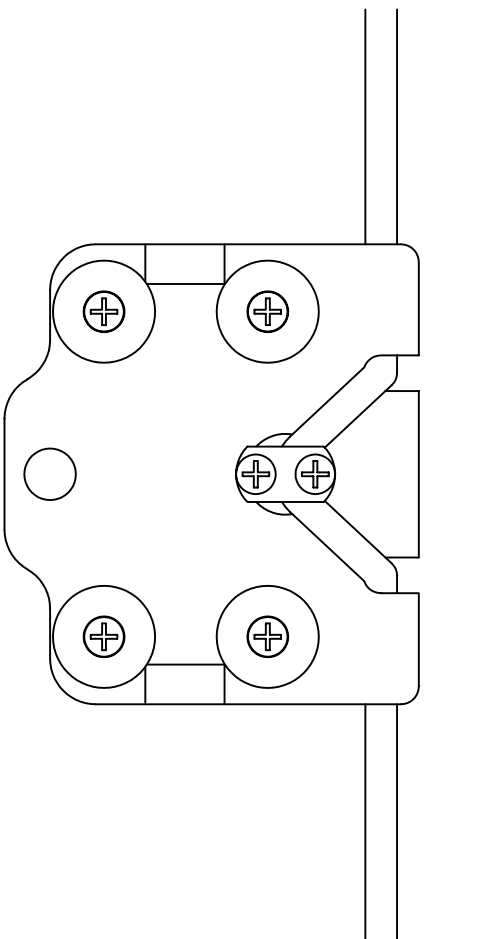

THESE VIEWS SHOW MASTER RUNNER CLAMPED ONTO CONTINUOUS LINE

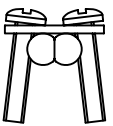
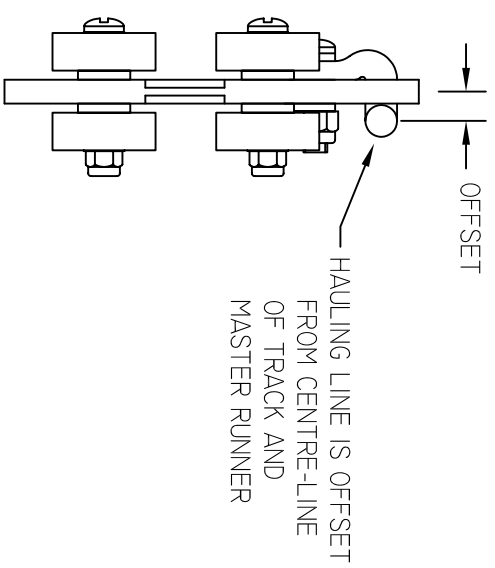

**STEP 1**  
 ASSEMBLE TWO CLAMP SCREWS THROUGH ONE CLAMP PLATE AND WEDGE THE TWO ENDS OF THE LINE BETWEEN SCREWS

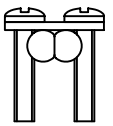

**STEP 2**  
 USE GENTLE FINGER PRESSURE TO SQUEEZE THE TWO CLAMP SCREWS UNTIL PARALLEL

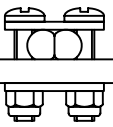

**STEP 3**  
 PUSH SCREWS THROUGH LARGE HOLE IN MASTER RUNNER AND FIT SECOND CLAMP PLATE AND TWO NUTS

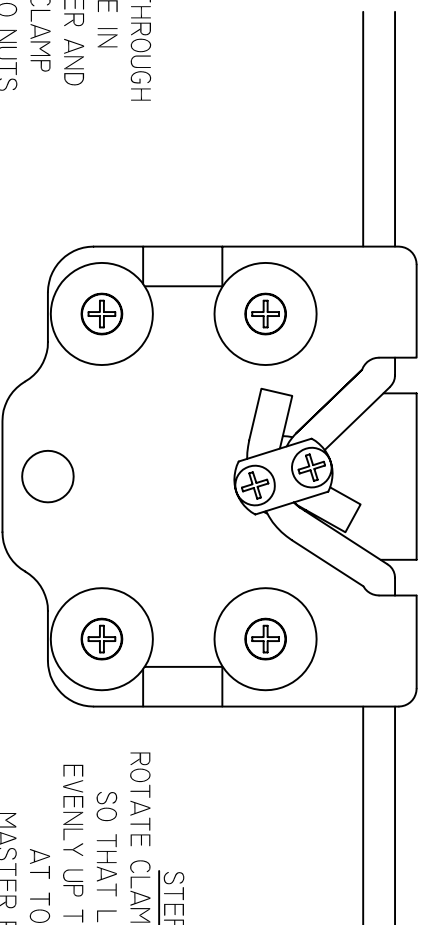

THESE VIEWS SHOW STEP BY STEP PROCEDURE TO ATTACH ENDS OF LINE TO MASTER RUNNER

**STEP 4**  
 ROTATE CLAMP ASSEMBLY SO THAT LINE RUNS EVENLY UP TO NOTCHES AT TOP OF MASTER RUNNER AND TIGHTEN SCREWS GENTLY TO SECURE ENDS OF LINE

FIG. 8 ~ ATTACH HAULING LINE TO MASTER RUNNERS

INSTALL BY FOUR EASY STEPS

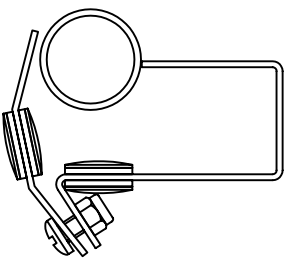

STEP 1  
PASS OVER TUBE WHEN  
SCREWS ARE STILL LOOSE

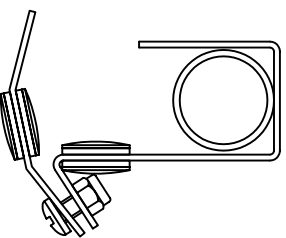

STEP 2  
REST DOWN  
ON TUBE

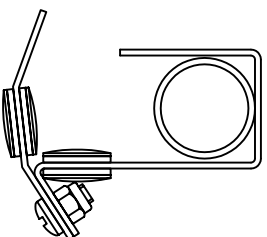

STEP 3  
TIGHTEN SCREWS

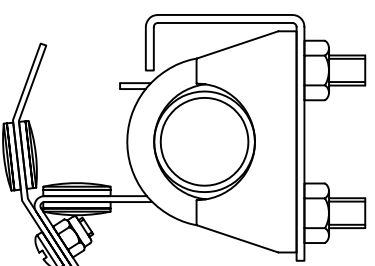

STEP 4  
FIT COVER  
IN PLACE  
USING 'U' BOLTS

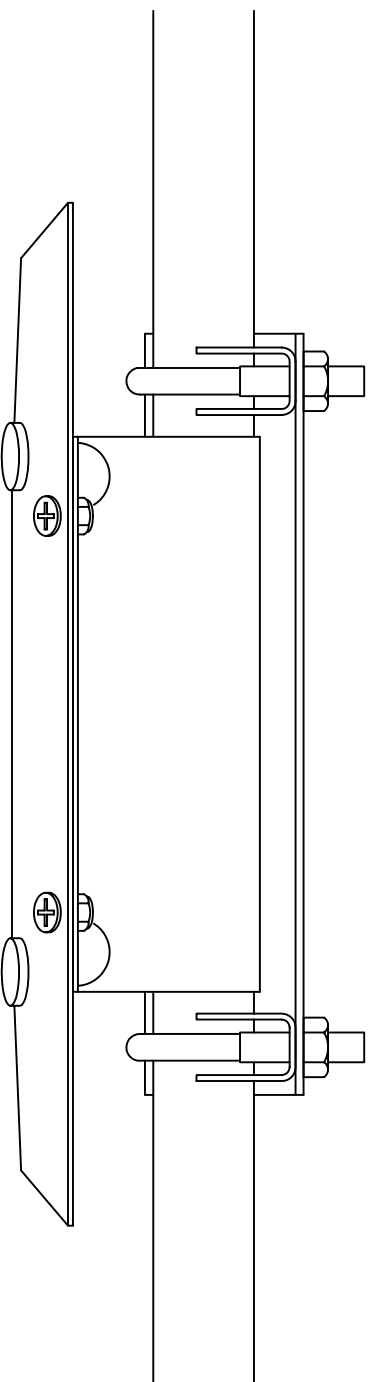
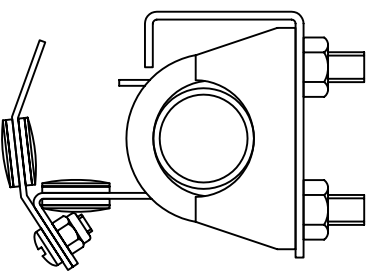

FIG. 9 ~ LINE SUPPORT T63770 CARRIED ON TOP TUBE OF TRACK

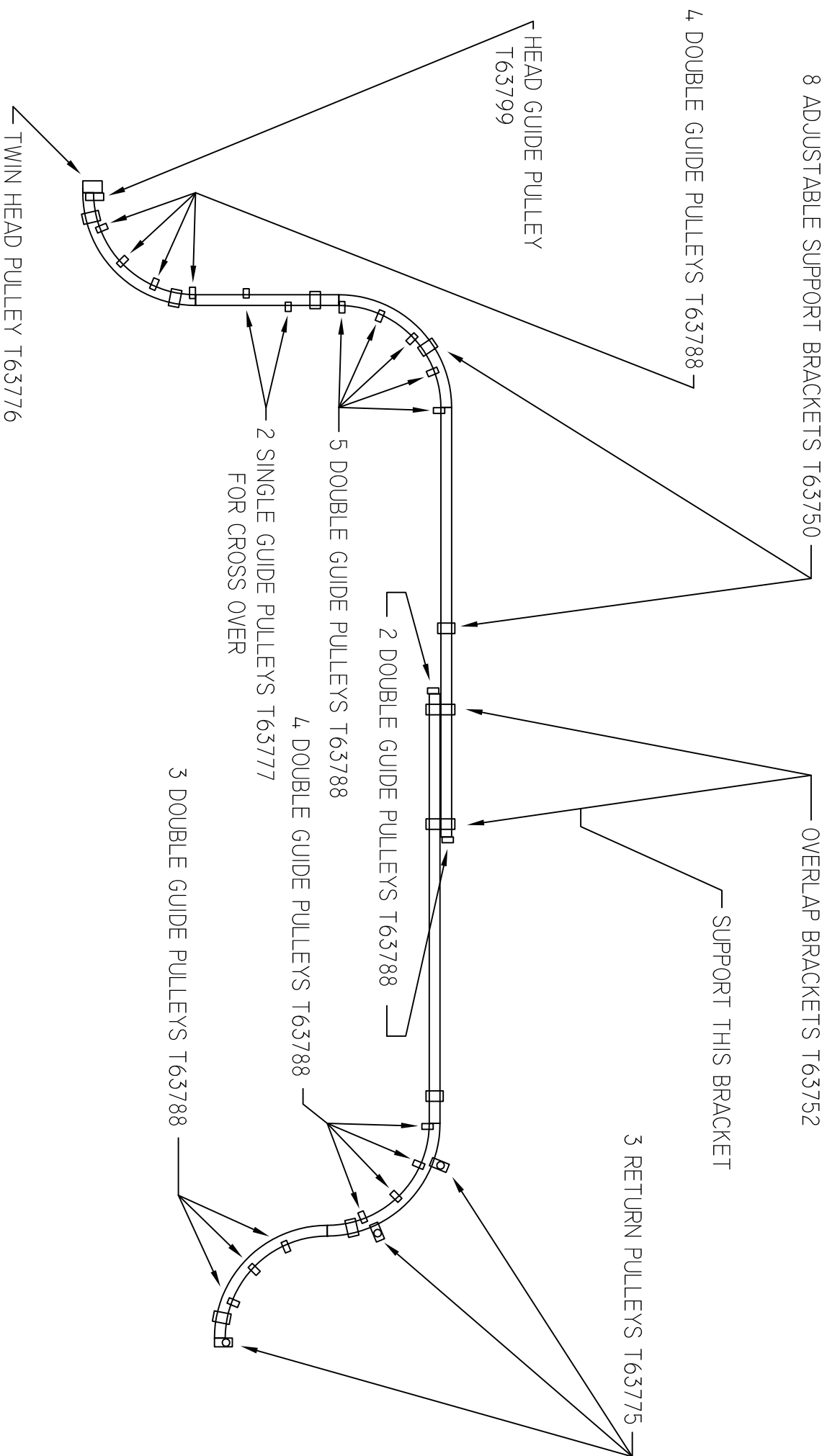
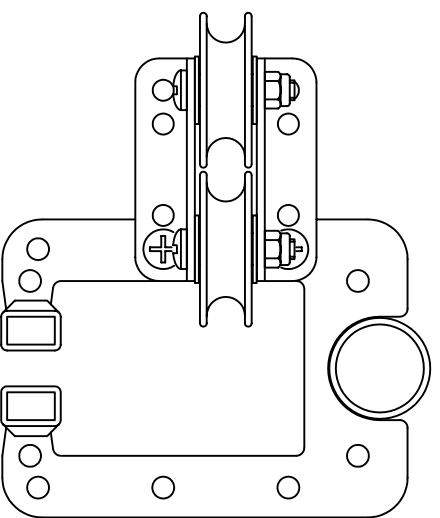
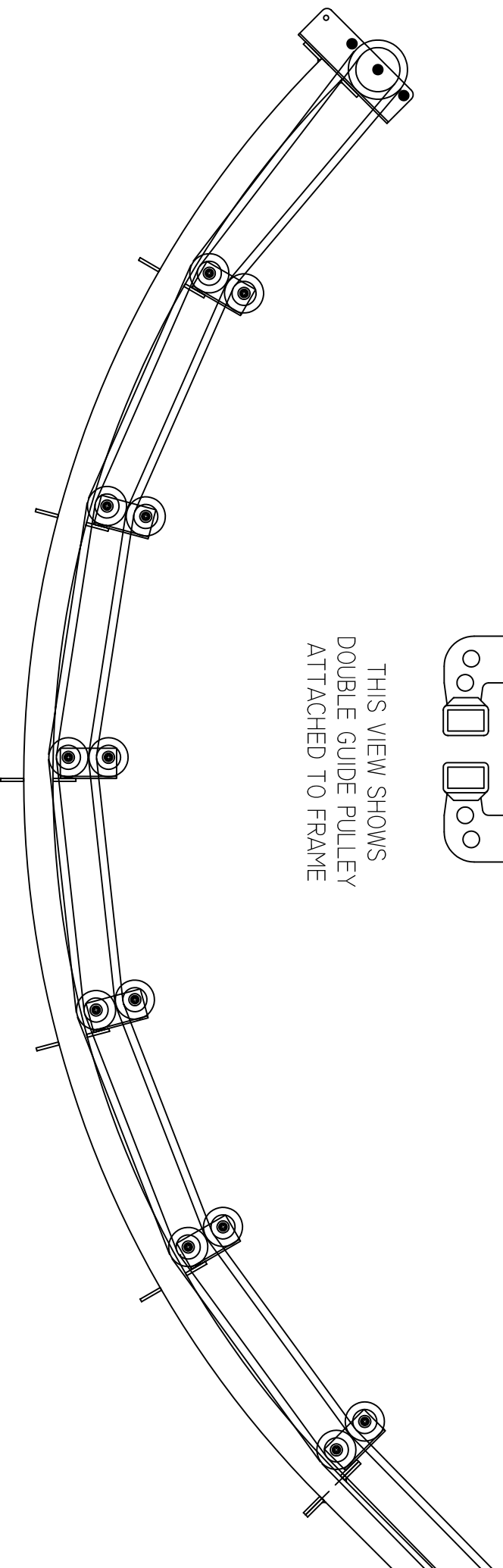

FIG. 10 ~ LAYOUT DIAGRAM WITH CURVES ~ PLAN VIEW.



THIS VIEW SHOWS  
DOUBLE GUIDE PULLEY  
ATTACHED TO FRAME



PLAN VIEW ALSO SHOWS RETURN PULLEY AND LINE

FIG. 11 ~ LAYOUT DIAGRAM SHOWING DOUBLE GUIDE PULLEYS INSIDE CURVE

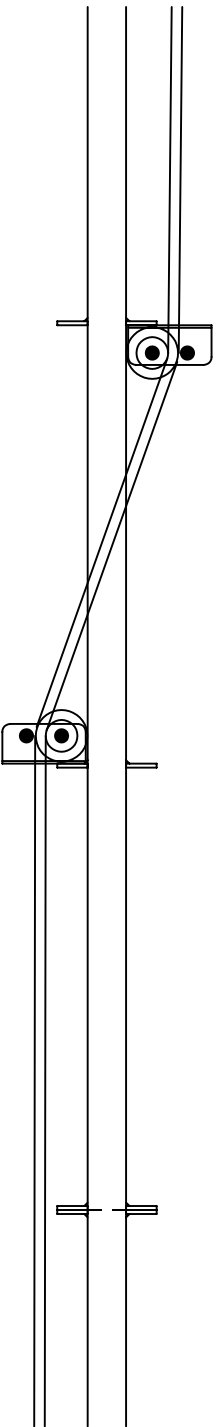

PLAN VIEW SHOWS TWO SINGLE GUIDE PULLEYS ARRANGED TO LEAD RETURN LINE TO OPPOSITE SIDE OF TRACK

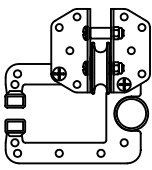

THIS VIEW SHOWS SINGLE GUIDE PULLEY ATTACHED TO FRAME FOR CROSS OVER

FIG. 12 ~ LAYOUT DIAGRAM SHOWING TWO SINGLE GUIDE PULLEYS FOR CROSS OVER

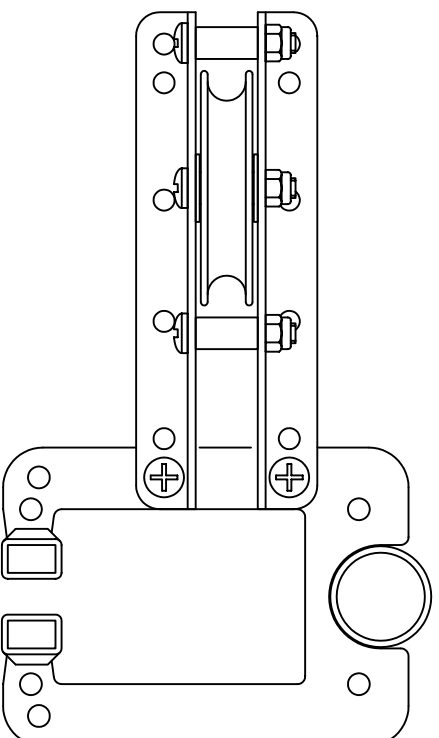

THIS VIEW SHOWS  
RETURN PULLEY  
ATTACHED TO FRAME  
OUTSIDE SECOND CURVE  
FOR RETURN LINE

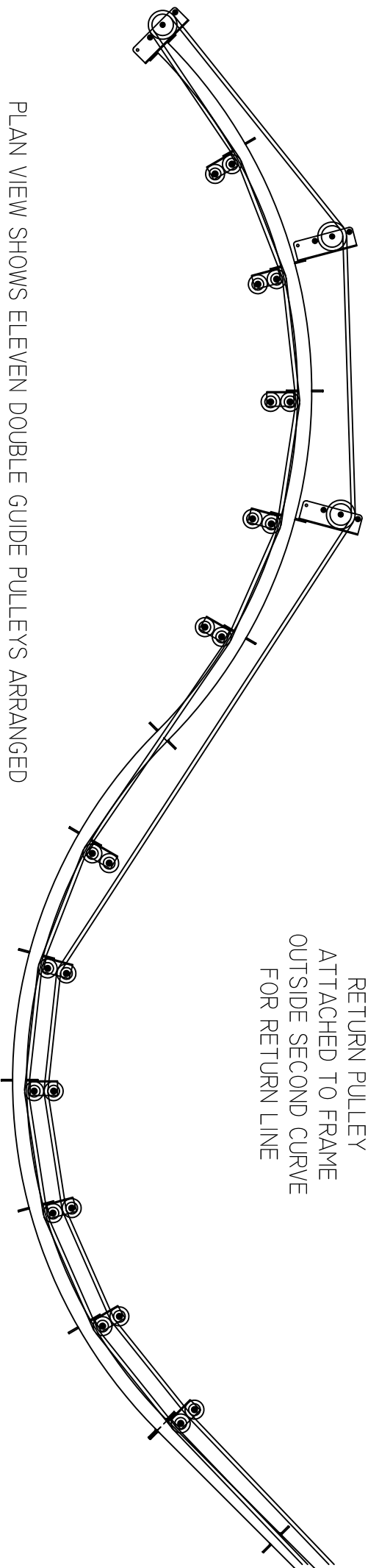

PLAN VIEW SHOWS ELEVEN DOUBLE GUIDE PULLEYS ARRANGED  
TO LEAD HAULING LINE THROUGH CURVES AND  
TWO EXTRA RETURN PULLEYS TO GUIDE THE RETURN LINE  
AROUND THE OUTSIDE OF THE SECOND CURVE

FIG. 13 ~ LAYOUT DIAGRAM SHOWING TWO CURVES IN 'S' FORMATION

TWIN HEAD PULLEY FITTED TO END OF TRACK  
WITH HEAD GUIDE PULLEY FITTED TO  
BACK OF FRAME AT END OF CURVE

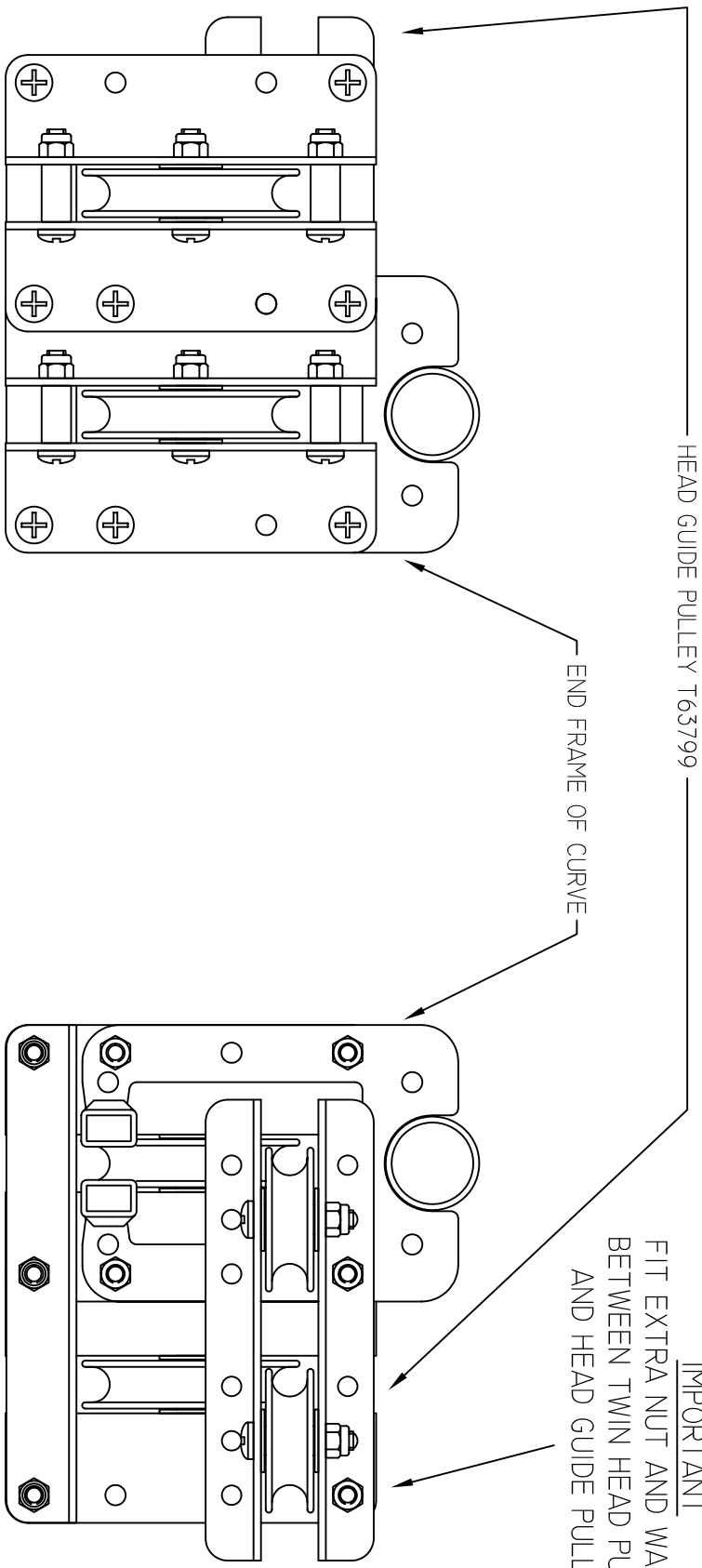

VIEW ON BACK

FIG. 14 ~ HEAD GUIDE PULLEY FITTED TO END OF CURVE WITH TWIN HEAD PULLEY

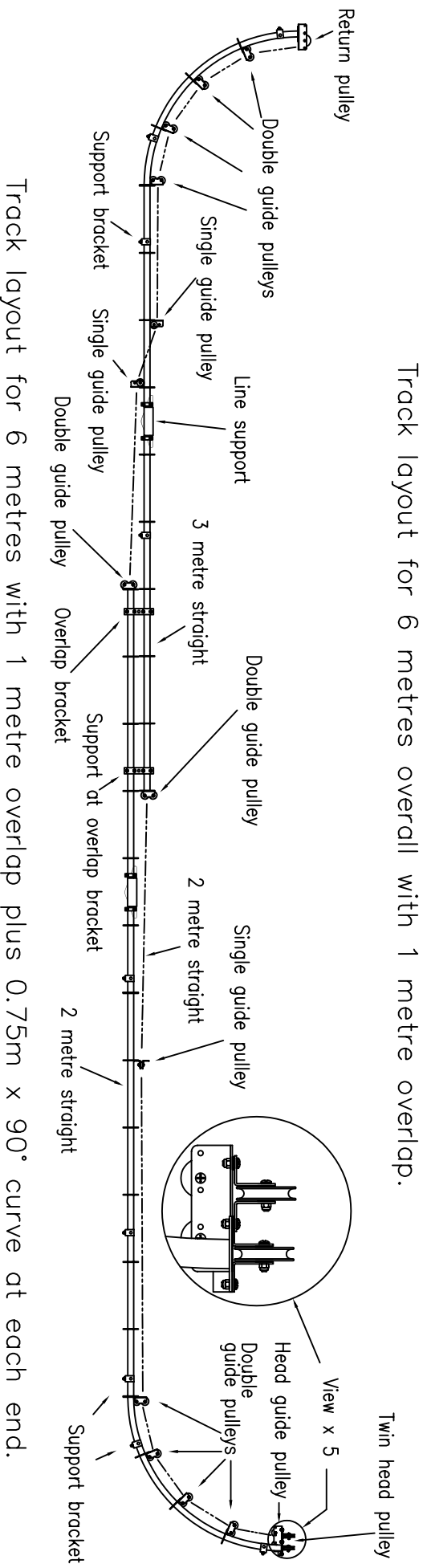
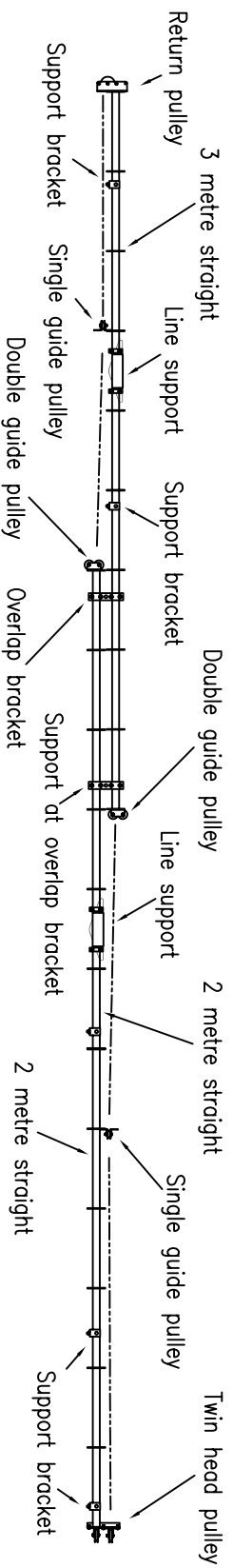
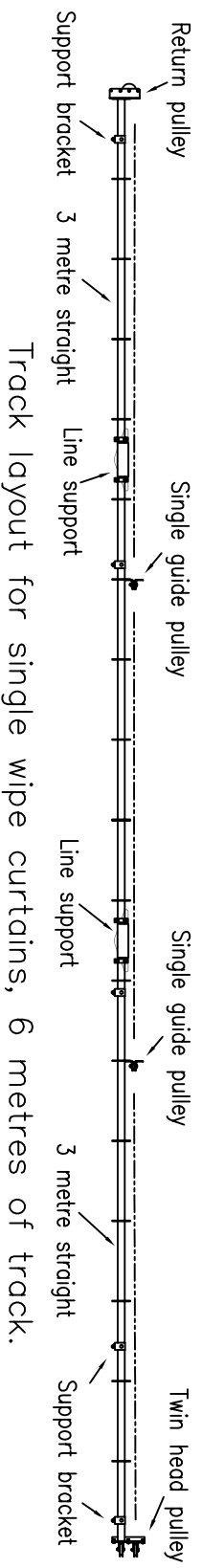

Fig. 15 – EXAMPLES OF TRACK LAYOUT