

PAR 16 Spot GU/GZ 10

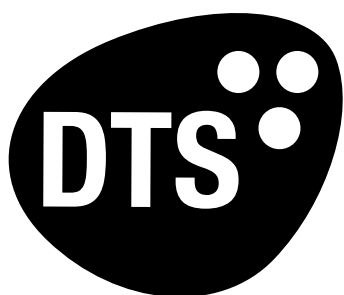
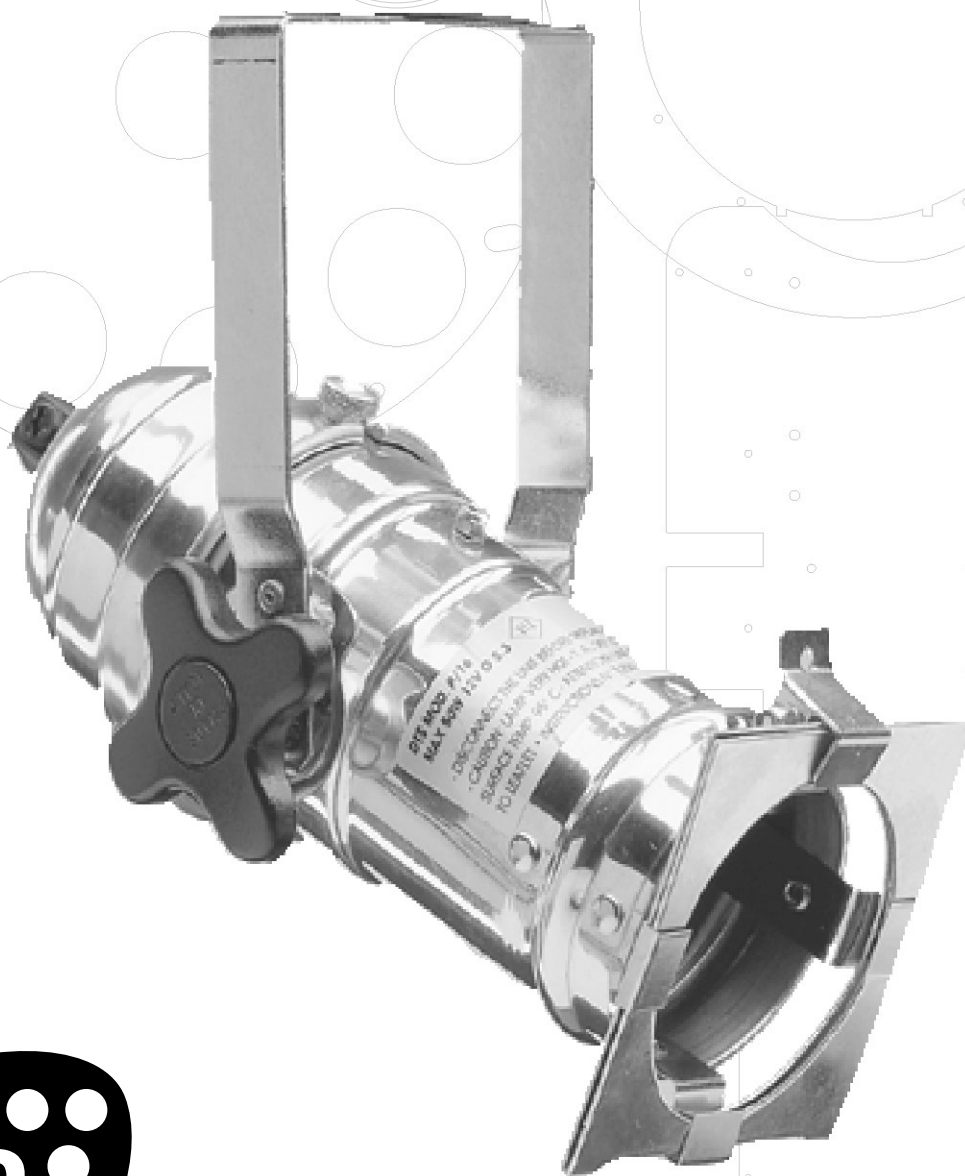
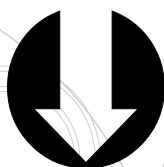

USER MANUAL

①

- 1) STAFFA
- 2) POMELLO
- 3) PARTE POSTERIORE
- 4) PARTE ANTERIORE
- 5) PORTAGELATINA
- 6) PORTALAMPADA GU/GZ 10

Ⓜ

- 1) BRACKET
- 2) KNOB
- 3) REAR PART
- 4) FRONT PART
- 5) GELATINE HOLDER
- 6) LAMPSOCKET GU/GZ 10

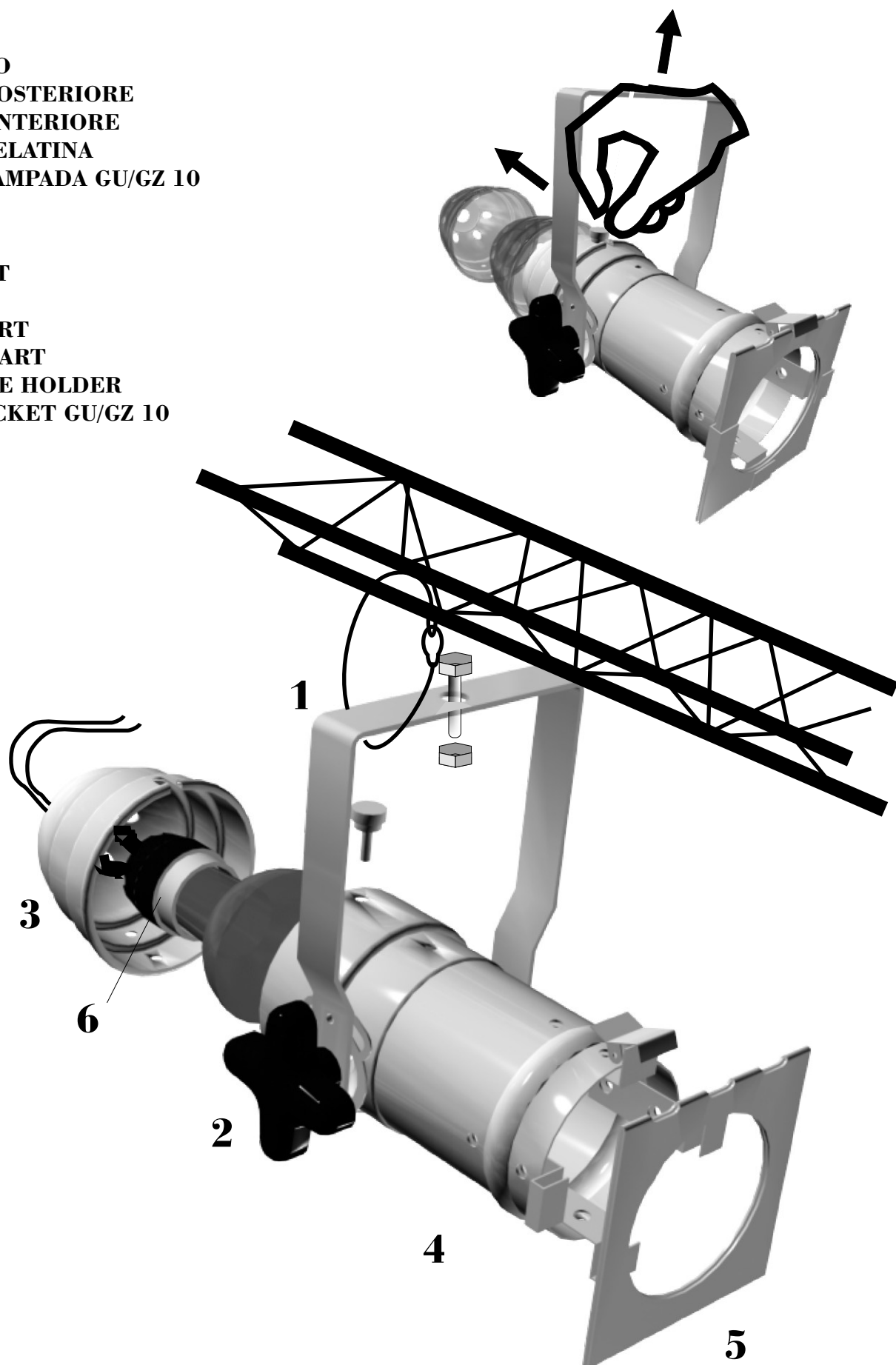

Istruzioni

La sicurezza dell'apparecchio è garantita solo con un uso appropriato delle seguenti istruzioni che quindi è bene conservare

LAMPADA: MR 16 GU/GZ 10 230V. - 50Hz. Max 50W.



Utilizzare solo lampade in regola con le normative anti scoppio

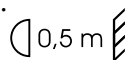

Distanza minima da tenere tra la lampada e l'oggetto illuminato.



Apparecchio idoneo all'installazione su superfici normalmente infiammabili.

ATTENZIONI:

- Scollegare l'alimentazione prima di sostituire la lampada.
- La lampada deve essere sostituita se danneggiata o se deformata dal calore.

MONTAGGIO:

- Per la connessione alla rete di alimentazione utilizzare una morsettiera per corrente almeno da 6A.
- Utilizzare un trasformatore di sicurezza.
- Nell'installazione utilizzare un sistema di ancoraggio ausiliario (cavetto in acciaio od altro sistema idoneo), oltre alla vite M8 utilizzata per ancorare la staffa.

Instructions

The device's security is assured only to an appropriate use following the instructions, therefore you suggest to keep them.

LAMP: MR 16 GU/GZ 10 230V. - 50Hz. MAX 50W.



Use only low pressur lamp according to the rules.

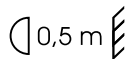

Minimum distance to be kept between the device and the lighted object.

The unit may be installed on normal inflammable surfaces.



WARNING:

Feeding devoice has to be followed trough a safety transformer
Disconnect the unit before replacing lamp
The lamp must be replaced if it has been damaged or waperd by heat.

ASSEMBLAGE:

- Connect the lamp socket cables to the safety transformer correctly by a connector (minimum 6A)
- Always install the fixture with an M8 wire an bracket as well as an additional safety sensity steel cable.

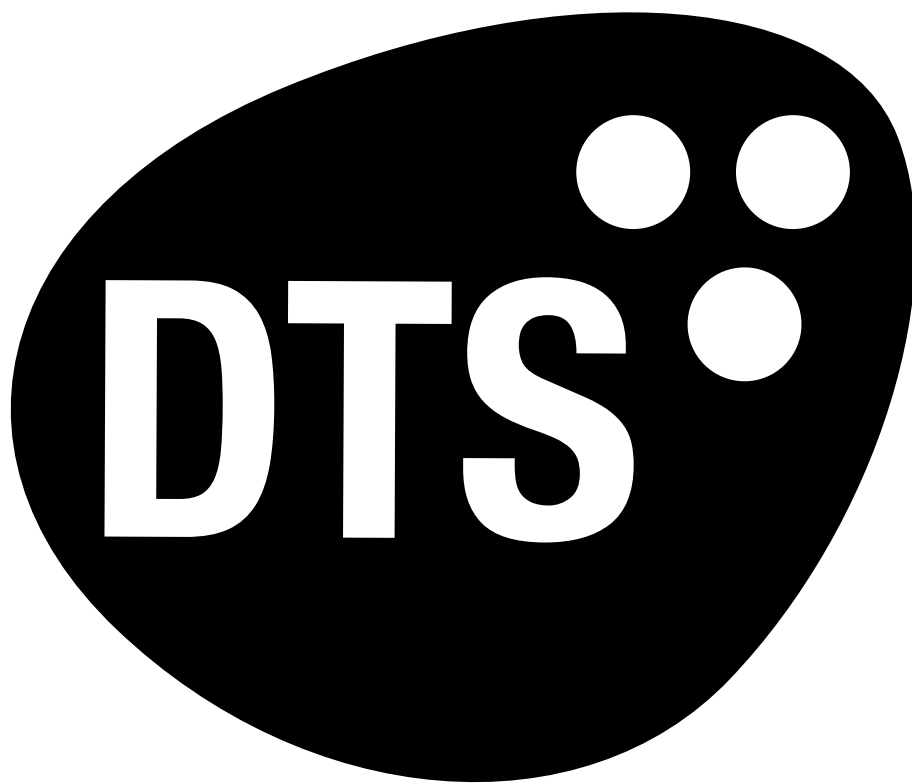

The Lighting Company