

# X R 7 S P O T



PROGETTO GRAFICO **D.T.S.** Show division



**D.T.S.**<sup>®</sup>  
Show division

# Moving head projector



**Le informazioni contenute in questo documento sono state attentamente redatte e controllate. Tuttavia non è assunta alcuna responsabilità per eventuali inesattezze. Tutti i diritti sono riservati e questo documento non può essere copiato, fotocopiato, riprodotto per intero o in parte senza previo consenso scritto della DTS .**

**DTS si riserva il diritto di apportare senza preavviso cambiamenti e modifiche estetiche , funzionali o di design a ciascun proprio prodotto. DTS non assume alcuna responsabilità sull'uso o sull'applicazione dei prodotti o dei circuiti descritti.**

**The information contained in this publication has been carefully prepared and checked. However, no responsibility will be taken for any errors. All rights are reserved and this document cannot be copied, photocopied or reproduced, in part or completely, without prior written consent from DTS.**

**DTS reserves the right to make any aesthetic, functional or design modifications to any of its products without prior notice. DTS assumes no responsibility for the use or application of the products or circuits described herein.**

**Les informations contenues dans le présent manuel ont été rédigées et contrôlées avec le plus grand soin. Nous déclinons toutefois toute responsabilité en cas d'éventuelles inexactitudes. Tous droits réservés. Ce document ne peut être copié, photocopié ou reproduit, dans sa totalité ou partiellement, sans le consentement préalable de DTS.**

**DTS se réserve le droit d'apporter toutes modifications et améliorations esthétiques, fonctionnelles ou de design, sans préavis, à chacun de ses produits. DTS décline toute responsabilité sur l'utilisation ou sur l'application des produits ou des circuits décrits.**

**Las informaciones contenidas en este documento han sido cuidadosamente redactadas y controladas. Con todo, no se asume ninguna responsabilidad por eventuales inexactitudes. Todos los derechos han sido reservados y este documento no puede ser copiado, fotocopiado o reproducido, total o parcialmente, sin previa autorización escrita de DTS.**

**DTS se reserva el derecho a aportar sin previo aviso cambios y modificaciones de carácter estético, funcional o de diseño a cada producto suyo. DTS no se asume responsabilidad de ningún tipo sobre la utilización o sobre la aplicación de los productos o de los circuitos descritos.**



## INDEX

|           |   |                |
|-----------|---|----------------|
| <b>1</b>  | <b>Technical features</b>               | <b>page 4</b>  |
| <b>2</b>  | <b>Safety information</b>               | <b>page 5</b>  |
| <b>3</b>  | <b>Mounting the lamps</b>               | <b>page 6</b>  |
| <b>4</b>  | <b>Voltage and frequency</b>            | <b>page 7</b>  |
| <b>5</b>  | <b>Installation</b>                     | <b>page 7</b>  |
| <b>6</b>  | <b>Mains connection</b>                 | <b>page 8</b>  |
| <b>7</b>  | <b>DMX signal connection</b>            | <b>page 9</b>  |
| <b>8</b>  | <b>Display functions</b>                | <b>page 11</b> |
| <b>9</b>  | <b>Error messages</b>                   | <b>page 14</b> |
| <b>10</b> | <b>Hidden menu</b>                      | <b>page 14</b> |
| <b>11</b> | <b>Opening the projector</b>            | <b>page 15</b> |
| <b>12</b> | <b>Replacing gobos</b>                  | <b>page 16</b> |
| <b>13</b> | <b>Periodic cleaning &amp; controls</b> | <b>page 17</b> |
|           | <b>Wiring connections</b>               | <b>page 18</b> |
|           | <b>DMX signal function</b>              | <b>page 20</b> |

# Moving head projector

# XLR7

GB

4

## 1- Technical Features

**New motorized rotating head**

**Abs covers**

**Both PAN and TILT are controlled by encoder**

**Pan: max movement 540° (8 or 16 bit)**

**Tilt: max movement 319° (8 or 16 bit)**

**Display for addresses and setting**

**Power supply: 230 V 50-60 Hz**

**Power consumption: 800 VA with in-built factor correction**

**Lamp: MSR 575/2 W discharge lamp**

**Control: max 16 channels DMX 512**

**Linear dimmer**

**Shutter: strobe max 10 flash/sec + strobe at random speed and evanescence (opening and closing) at 4 different speeds**

**Colours: 8 dichroic filters with high chromatic yield + white, 9 different rotating speeds to produce Rainbow effect.**

**Gobos: 7 rotating and indexable gobos + open**

**3 sides prism (angle 14°) with different rotation speed to right or left**

**Motorized focus**

**Frost**

**3 light beam angles (13°/18°/21°)**

**Optical system: 3 lenses with double antireflective treatment**

**Working position: any position**

**Weight: 26 kg**



# Moving head projector



## **2- IMPORTANT SAFETY INFORMATION**

### **2.1 Fire prevention:**

1. XR7 uses a Philips 575 MSR/2 or MSD 575/2 lamp. The use of any alternative lamp is not recommended and will null and void the fixture's warranty.
2. Never locate the fixture on any flammable surface.
3. Minimum distance from flammable materials: 0.5 m.
4. Minimum distance from the closest illuminable surface: 2 m.
5. Replace any blown or damaged fuses only with those of identical value. Refer to the wiring diagram if there is any doubt.
6. Connect the projector to mains power via a thermal magnetic circuit breaker.

### **2.2 Prevention of electric shock:**

1. High voltage is present inside the unit. Isolate the projector from the mains supply prior to performing any function which involves touching the inside of the unit, including lamp replacement.
2. The level of technology inherent in the XR7 requires the assistance of specialised personnel for all servicing. Refer all work to your authorised DTS service centre.
3. A good earth connection is essential for proper functioning of the projector. Never connect the unit without proper earth connection.
4. The fixture should never be located in a position exposed to rain or in areas of extreme humidity. A steady supply of circulating air is essential.

### **2.3 Protection against ultraviolet radiation:**

1. Never turn the lamp on if any of the lenses, filters or the carbon fibre housing is damaged. Their respective shielding functions will only operate efficiently if they are in perfect working order.
2. Never look directly into the lamp when it is on.

### **2.4 Safety:**

1. The projector should always be installed with bolts, clamps and other fixtures that are capable of supporting the weight of the unit.
  2. Always use a second safety chain of a suitable rating to sustain the weight of the unit in case of the failure of the main fixing point.
  3. The external surface of the unit, at various points, may exceed 150°C. Never handle the unit until at least 10 minutes have elapsed since the lamp was turned off.
  4. Always replace the lamp if any physical damage is evident.
  5. Never install the fixture in an enclosed area lacking sufficient air flow. The ambient temperature should not exceed 35°C.
  6. A hot lamp may explode, so always wait for at least 10 minutes to elapse after the unit has been turned off prior to attempting to replace the lamp.
- Always wear suitable hand protection when handling the lamp.

### **2.5 Level of protection against the penetration of solid and liquid matter**

- 1) The projector is classified as an ordinary appliance and its level of protection against the penetration of solid and liquid matter is IP 20. XR7 uses 575W Philips 575 MSR/2 lamps with GX 9.5 base.

# Moving head projector



The temperature inside the projector can reach 250° C after just 5 minutes, but it can get as high as 350° C. Always check that the lamp is cold before attempting to remove it. In any case, only open the appliance 10 minutes after it has been turned off.

## 3- Mounting the lamps

**Warning: turn power off before opening the appliance.**

Philips 575 MSR/2

Power 575W

Luminous flux 49,000 lm

Colour temperature 7.200°K

Lampbase GX9,5

Rated life 1,000 hours

1) Using a head screwdriver, remove the 3 screws (X,Y, Z) (photo 1, black screws) which hold the lampholder in place and are located at the rear of the projector head.



Photo 1



Photo 2

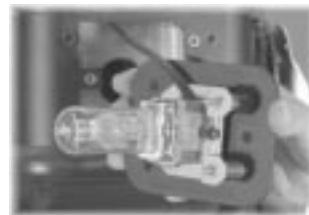

Photo 3



Photo 4

2) Remove the lampholder unit. Locate the lampholder (photo 2).

3) Insert the lamp (photo 3).

The lamp used is manufactured from quartz glass and should be handled with care. Always adhere to the instructions supplied in the lamp's packaging. Never touch the glass directly but use the tissue provided in the lamp's packaging. The GX 9.5 lampbase is symmetrical.

**DO NOT USE UNDUE FORCE ON THE GLASS.** In case of difficulty, re-read the instructions and repeat the procedure.

4) Replace the lamp assembly (photo 4) and replace and tighten the screws (X,Y,Z), which were previously removed (photo 1).

### 3.1 Alignment lamp

**Attention:** we recommend that the lamp be realigned in the optical train of the unit to avoid overheating of the dichroic filters and other components inside the unit. (Photo 5).



Photo 5

Alignment is carried out using the 3 adjusters A, B and C (white screws).

During this operation you must bring the hot-spot to the centre of the beam and flatten it as much as possible.

# Moving head projector



## 4- Voltage and frequency

The projector can operate at 230V voltage, at 50 or 60 Hz. D.T.S. presets a voltage of 230V at a frequency of 50Hz (barring specific requests).

## 5- Installation

XR7 may be either floor or ceiling mounted.

For floor mounting installations, the XR7 is supplied with four rubber mounting feet (B) on the base.

For ceiling mounted installations, we suggest the use of appropriate clamps or fixings to attach the fixture to the mounting surface.

The supporting structure from which the unit is hung should be capable of bearing the weight of the unit, as should any clamps used to hang it. The structure should also be sufficiently rigid so as not to move or shake whilst the XR7 moves during its operation.

Four quarter turn fast locks placed on the base of the units allow for the fixing of brackets that can then be fixed on to the rails with the use of C clamps or Aliscraf type clamps.

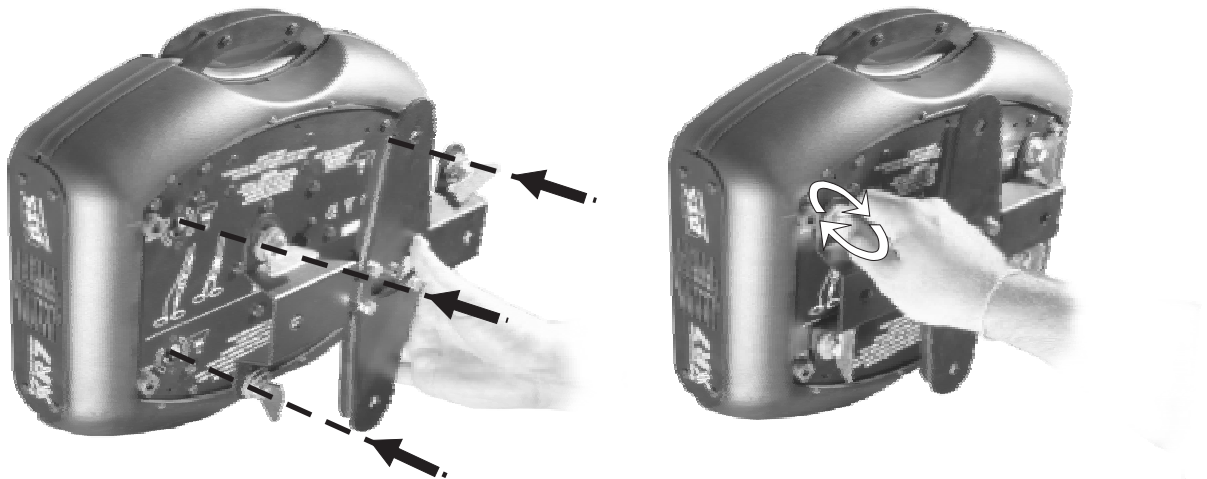

## Safety chain

We recommend the use of a safety cable or chain connected to the XR7 and to the suspension truss in order to avoid the fixture accidentally falling should the main fixing point fail. Make sure that the iron cable or chain can bear the weight of the entire unit.

You may attach the safety chain to the two holes (A) located on the base of the fixture, as shown in the diagram below.

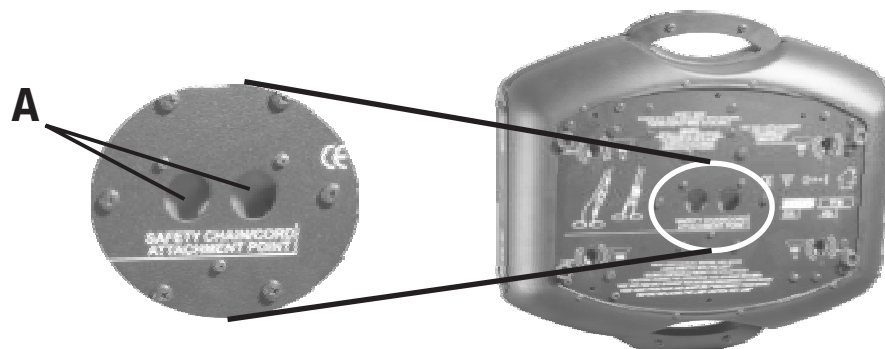

## Protection against liquids

The projector contains electric and electronic components which should under no circumstances come into contact with oil, water or any other liquid. The proper working of the unit would be compromised should this occur.

# Moving head projector



## Movement

The projector has a maximum movement of 540° in the base and 319° in the yoke. **DO NOT** place any obstructions in the path of the projector's movement.

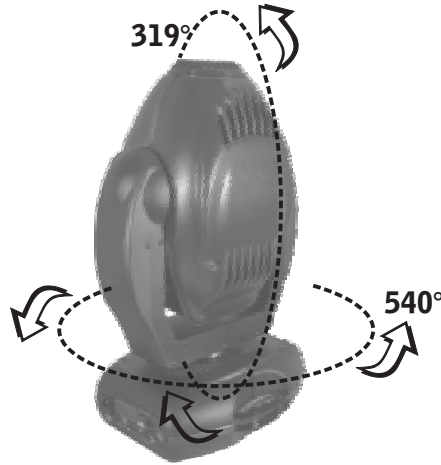

## Risk of fire

Each fixture produces heat and must be installed in a well-ventilated position. The minimum recommended distance from flammable material is 0.5m. Minimum distance from the object being illuminated is 2 m.

## Forced ventilation

You will note, on inspection, that the fixture features various air inlets and cooling fans located on both the base and head of the fixture. These should, under no circumstances, be blocked or obstructed whilst the projector is in operation.

Doing so could cause the fixture to seriously overheat thereby compromising its proper operation.

## Ambient temperature

The projector should never be installed in places that lack a constant flow of air. The ambient temperature should **NOT** exceed 35°C.

## 6- Mains connection

XR7 operates at voltage 230V at 50 or 60Hz.

Prior to connecting the unit to your mains supply, ensure that the model in your possession correctly matches the mains supply available. For connection purposes, ensure that your plug is of a suitable rating of 8 amps at 230V.

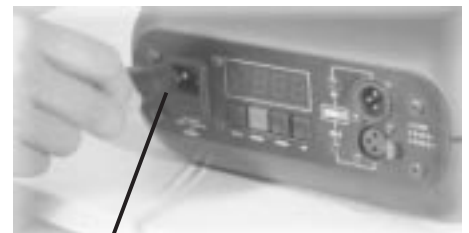

230V 50 / 60Hz

Strict adherence to regulatory norms is strongly recommended.

## Protection

The use of a thermal magnetic circuit breaker is recommended for each XR7.

A good earth connection is essential for the correct operation of the projector.

## 7- DMX signal connection

The unit operates using a digital DMX 512 (1990) signal. Connection between the control box and

# Moving head projector



the projector or between projectors must be carried out using a two pair screened  $\varnothing 0.5$  mm cable and a CANNON XLR 5 or 3 pole connector.

Ensure that all conductors are isolated from one another and from the metal plug housing. The plug housing must be isolated. Connect the control box signal to the DMX IN projector plug and connect it to the next projector by connecting the DMX OUT plug on the first projector to the DMX IN plug on the second.

In this way, all the projectors are cascade connected.

**NB.** If the display showing the DMX address flashes, then one of the following errors has occurred:

- DMX signal not present
- DMX address not valid
- DMX reception problem

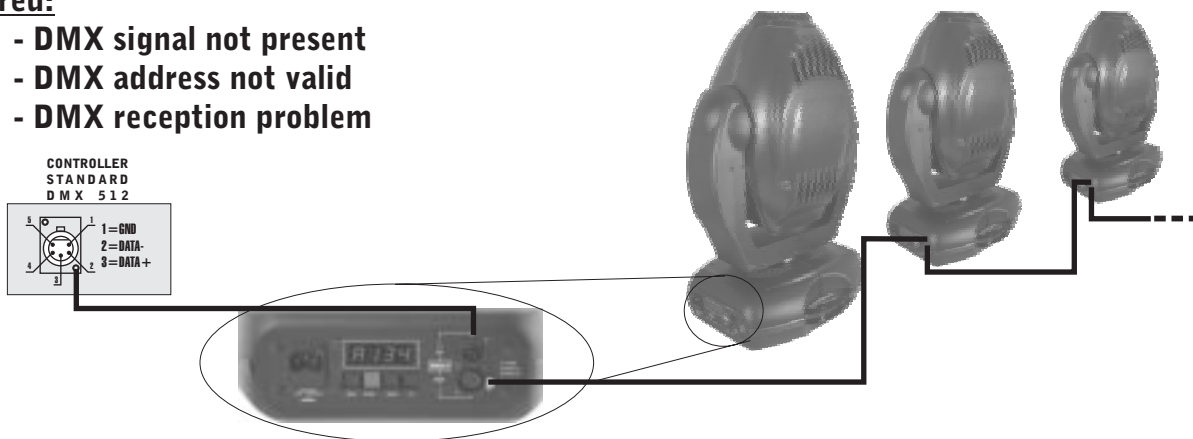

Install when the signal wire has to be put in long distances or where there are electrical disturbances for example in a disco, concert, theater etc we advise to use a dmx terminal. the dmx terminal or even more a canon xrl-5 connected with a resistance to 120 ohm between 2 and 3 the resistance is put in the plug of the dmx of the last device that has been linked as shown following.

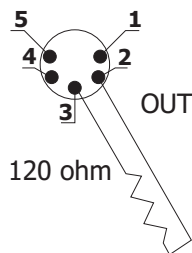

ATTACHMENT OF THE TERMINAL DMX INSTALL A RESISTANCE OF 120(OHM) BETWEEN 2 AND 3 IN THE PLUG XRL AND INSERT IN THE DIGITAL PLUG OUT OF THE LAST DEVICE OF THE ROW

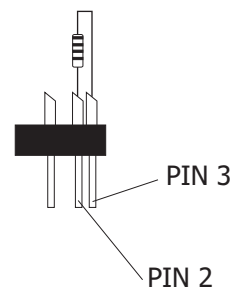

The standard configuration of the XR7 is with XLR 5 pole connection.

To convert to an XLR 3 pole configuration proceed as follows:

- 1) Unscrew the external cover (photo 1).
- 2) Unscrew the screws that fix the connectors to the panel (photo 2).
- 3) Rotate the electronic card by 180° (photo 3).
- 4) Position the 3 pole connectors in the special holes and close.



Photo 1



Photo 2



Photo 3

# Moving head projector



## DMX Addresses

XR7 can be used in three different modes: 8, 10 or 16 DMX channels.

If you want to use a DMX controller with 8 channels, select the 8 CH mode from the MODE menu and set the following addresses:

Projector 1 A001  
Projector 2 A009      If you want to select the next projector, just add "8"  
  
Projector 3 A017  
..... A....  
projector 6 A041

If you want to use a DMX controller with 10 channels, select the 10 CH mode from the MODE menu and set the following addresses:

Projector 1 A001  
Projector 2 A011      If you want to select the next projector, just add "10"  
  
Projector 3 A021  
..... A....  
Projector 6 A051

If you want to use a DMX controller with 16 channels, select the 16 CH mode from the MODE menu and set the following addresses:

Projector 1 A001  
Projector 2 A017      If you want to select the next projector, just add "16"  
  
Projector 3 A033  
..... A....  
Projector 6 A081

The address that has to be set on each projector generally depends on the number of channels that the DMX mixer allots it.

If you have a 12 channel controller, set your XR7 to 10 CH MODE. The first projector will have an A001 address and if you want to select the next projector, then you have to add 12.

## Changing the DMX address

1) Press the UP-DOWN key until you reach the required DMX number. The numbers on the display

# Moving head projector

# XR7

GB

11



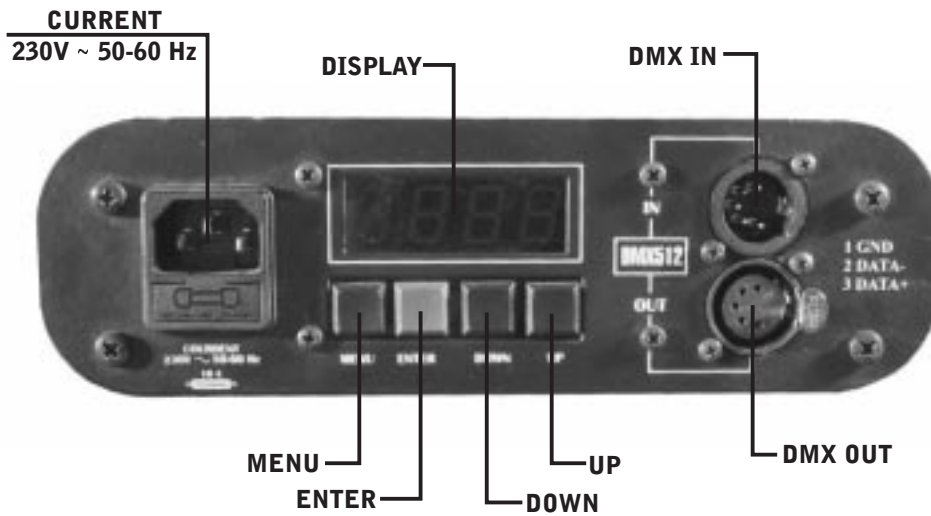

































## 8- DISPLAY FUNCTIONS



## DISPLAY FUNCTIONS

The XR7 display panel shows all the functions available. Using these functions, it is possible to change some of the parameters and to add some functions. Changing the DTS setting can vary the functions of the appliance so that it does not respond to the DMX 512 used to control it. Carefully follow the instructions below before carrying out any variations or selections.

**NOTE:** the symbol  shows which key has to be pushed to obtain the function desired.

|   |   |   |   |  |  |                                 |
|---|---|---|---|--|--|---------------------------------|
|  |   |  |   |  | Clockwise  |                                 |
|   | <b>PAN MOVEMENT INVERSION</b><br>To reverse horizontal direction of the beam from left to right and vice versa on DMX level variation.                                  |   |   |   |  | Counterclockwise                |
|   |   |  |   |  | Clockwise  |                                 |
|   | <b>TILT MOVEMENT INVERSION</b><br>To reverse vertical direction of the beam from the bottom upwards and vice versa on DMX level variation                               |   |   |   |  | Counterclockwise                |
|   |   |  |   |  | Floor position   |                                 |
|   | <b>REVERSE DISPLAY</b><br>Reverses display's reading depending on the mounting position (on the ground or suspended).   |   |   |   |  | Suspension position             |
|   |   |  |   |  | 16 CHANNELS (Pan & Tilt 16 bit)  |                                 |
|   | <b>DMX MODE</b><br>To select DMX mode : 8-10-16-14 channels   |   |   |   |  | 10 CHANNELS (Pan & Tilt 16 bit) |
|   |   |   |   |   |  | 8 CHANNELS (Pan & Tilt 8 bit)   |
|   |   |   |   |   |  | 14 CHANNELS (Pan & Tilt 8 bit)  |

# Moving head projector

# XLR7

GB

12

MENU UP-DOWN TEST ENTER TEST

**TEST MODE**  
Device operation test.

MENU UP-DOWN AUTO ENTER SUR-E ENTER UP-DOWN CAN1 }  
MENU UP-DOWN CAN2 } ENTER SPEED  
MENU UP-DOWN CAN3 } ENTER FOCUS  
MENU UP-DOWN GAM.P ENTER SPEED  
MENU UP-DOWN ESC

MENU UP-DOWN RESE ENTER RESE

**RESET**  
To reset all motors function

MENU UP-DOWN DFSE ENTER SUR-E ENTER

**DEFAULT**  
To restore default setting (set by DTS)

MENU UP-DOWN SOFT ENTER 14.11

**SOFTWARE VERSION** Pcb 8 motors. Pcb PAN&TILT  
Electronic card software version.

MENU UP-DOWN FANS ENTER UP-DOWN 1 ENTER  
MENU UP-DOWN FANS ENTER UP-DOWN 12 ENTER

**Fan control**  
To control the fan speed .

MENU UP-DOWN TIME ENTER UP-DOWN LAMP ENTER  
MENU UP-DOWN TIME ENTER UP-DOWN Unit ENTER  
MENU UP-DOWN TIME ENTER UP-DOWN RESEL ENTER

**TIMER**  
Visualization of lamp life (reset possible)  
and total time unit's working (reset not possible)

MENU UP-DOWN SPEE ENTER UP-DOWN 1 ENTER  
MENU UP-DOWN SPEE ENTER UP-DOWN 4 ENTER

**SPEED**  
To change the maximum speed of  
PAN and TILT movement

MENU UP-DOWN LAMP ENTER dnH ENTER ON / OFF VIA DMX (default)  
MENU UP-DOWN LAMP ENTER UP-DOWN on ENTER FORCED ON)  
MENU UP-DOWN LAMP ENTER UP-DOWN off ENTER FORCED OFF

**LAMP ON/OFF lamp**

MENU UP-DOWN roto ENTER UP-DOWN on ENTER  
MENU UP-DOWN roto ENTER UP-DOWN off ENTER

**Gobo Rotation**  
Activates roto gobos during the gobo change

MENU UP-DOWN REC ENTER UP-DOWN 16CH ENTER r.017  
MENU UP-DOWN REC ENTER UP-DOWN 10CH

**REC**  
Record mode

MENU UP-DOWN SLAU ENTER SUR-E ENTER UP-DOWN SLU  
MENU UP-DOWN SLAU ENTER UP-DOWN ESC

**Slave**  
Slave mode as run by GAM.P, Synchronised with master

# Moving head projector



## Automatic operation (auto)

XR7 can work in automatic mode without a DMX controller.

First of all connect the projectors with a DMX cable (picture below).

### MASTER

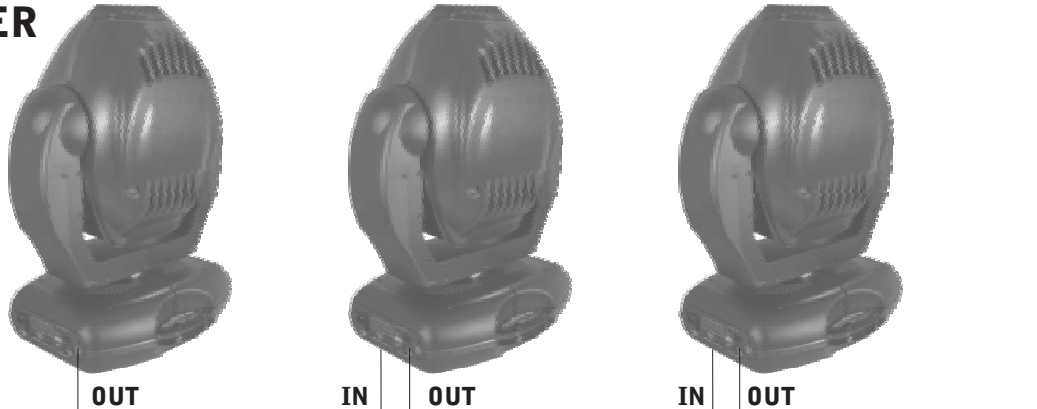

To activate Auto mode on the first unit, use the menu to run through the different modes until **AUTO** appears on the display, at this point press enter.

Now it is possible to choose between the different pre-programmed games (**GAME 1-2-3**) or Game **P** which is user programmable through **REC** mode. To confirm game activation press **ENTER** on the chosen **GAME**.

### GAME 1-2-3

The first unit that will work as a Master should be placed in Automatic mode (**AUTO**), the other projectors have to be placed in 16 channels DMX mode (**MODE 16CH**) and the DMX address should be set at **A001**. Once a game is chosen and set it is possible to select the speed of the game (**SPEE**) and the gobo focus (**FOCU**).

### GAME P

The first unit that will function as a Master must be put in (**AUTO**) mode, the other projectors have to be put in slave mode (selectable through the menu). In this way all units will be synchronised with the master, the projectors need not be of the same model.

On the master unit it is possible to vary the speed of the **GAME P (SPEE)**

**NB:** It is possible to run **GAME P** on the other units even though these do not have **GAME P** programmed. You can do this by setting the units to the same mode as the master is set before programming **GAME P (10CH or 16CH DMX)** and selecting **A001** as the DMX address.

### REC MODE

It is possible to programme your own game on the XR7 that will then run in **AUTO** mode (**GAME P**). Each unit can have its own programmed game.

In **REC** mode each projector must be set to the same mode (**10CH or 16CH DMX**).

For the programming of **GAME P** besides the channels necessary to control the unit a further 3 DMX channels are needed. So that in **REC** mode if the **10CH** mode is selected you will need 13 channels for the programme to work correctly whereas **16CH** mode would occupy 19 channels. Connect the unit to a DMX mixer/controller, every unit should be set to its own Address (See the paragraph on DMX addresses). The projectors can also be different of models: XR7 spot/wash and XR 250 spot/wash. When you are in **REC** mode **R.001** appears on the display (DMX address).

# Moving head projector



The three new DMX channels are:

## -Scene channel

-Form 0-255 are displayed the programmable scenes (max 16 scenes M.001 M016)

## -View channel:

-From 1-19 the unit runs the scene that has been saved in the units memory and it is possible to play through the other scenes using the scene channel.

-From 20-235 the unit runs the configuration given by the received input DMX values. With the channel scene it is possible to pass from one scene to the next while with REC it is possible to record the selected scene.

-From 236-255 the unit runs the configuration given by the received DMX values from the projector in that moment. It is possible to select a scene and then close the GAME P with the REC channel.

## -Recording channel (REC)

Records the set scene with a variable between 0 and 255 (the display flashes indicating that the scene has been recorded).

It is advised that you keep the REC channel set to 0 and to run through the 255 only once you have decided to save the scene. If GAME P is not closed, by indicating the last scene, in playback mode all 16 scenes will be played through even if not programmed.

## Pan & Tilt speed (SPEE) (default: 2)

You can set the PAN and TILT engines at high speed on your XR7.

Press menu until you see SPEE.













Press ENTER and select a speed with UP-DOWN (there are 4 speeds). Confirm by pressing ENTER.

When you use speed 4 (the highest) PAN and TILT speed is very high and your projector may loose its path. In this case, the encoder corrects the position.

## Fan speed (FANS)( default: 12)

Fan speed regulation makes it possible to reduce fan noise. However, the ambient temperature must be less than 35° C.

## 9- ERROR MESSAGES:

|  |  |   |                                 |
|--|--|---|---------------------------------|
|  | — ERROR: ENCODER PAN   |  | — ERROR: colour WHEEL POSITION  |
|  | — ERROR: ENCODER TILT  |  | — ERROR: GOBO WHEEL POSITION    |
|  | — ERROR: DMX ADDRESS   |  | — ERROR: LENSES WHEEL POSITION  |
|  | — ERROR: LOAD DATA EEPROM  |  | — ERROR: ROTOGOBO POSITION      |
|  | — ERROR: SENSOR CIRCUIT COLOR/BEAM ANGLE                         |  | — ERROR: INTERNAL COMMUNICATION |
|  | — ERROR: SENSOR CIRCUIT GOBO/ROTOGOBO                            |  | — ERROR: AUTO MODE INPUT        |
|  | — ERROR SYNCHRONIZED FREQUENCY MEASURE (SYNCHRONISM FOR LAMP ON) |   |                                 |

# Moving head projector



## 10- HIDDEN MENU

For technical personnel only.

To operate this menu:

-Connect the projector to the DMX controller (DMX SIGNAL MUST BE CORRECTLY RECEIVED)

- Reset the XR7 (reset from the display projector, not from the DMX controller!).
- While reset is working, press the MENU and ENTER keys at the same time.

**CAL** Electronic calibration of the motors.

**RESN** Reset EEPROM (Reset all settings. ATTENTION: by pressing this key you must repeat all previous calibrations)

**ESC** Exit from hidden menu.

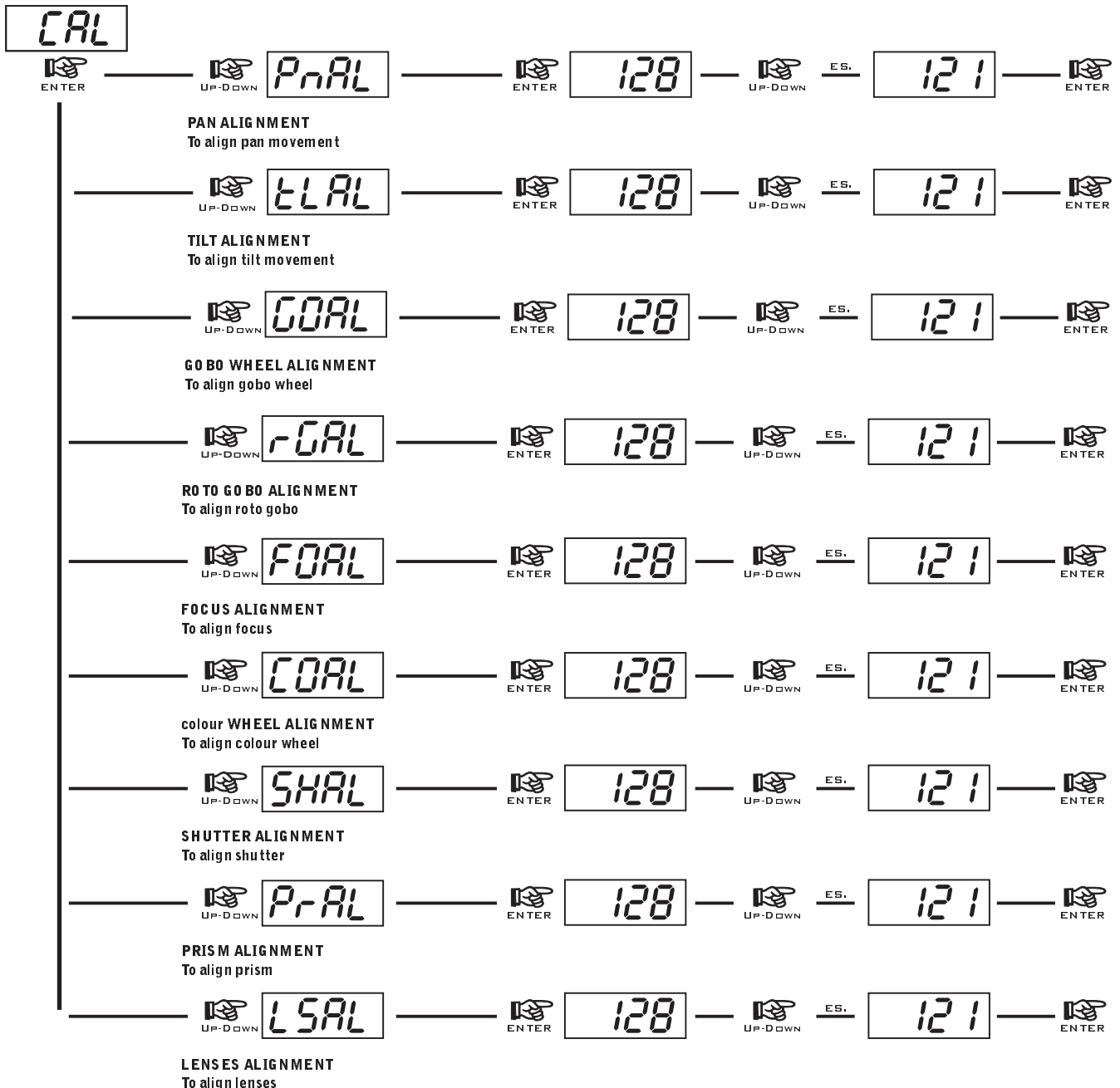

## 11- Opening up the projector housing

It is possible to inspect the inside of the projector by removing the cover as indicated below.

### Attention

**REMOVE MAINS POWER PRIOR TO ACCESSING THE PROJECTOR'S INTERNAL COMPONENTS.**

- 1) Loosen the screws which fix the upper and lower covers (photo 1) and unscrew the side covers (photo 2).
- 2) Once unscrewed, simply lift the covers to access the internal components (photo 3).



Photo 1



Photo 2

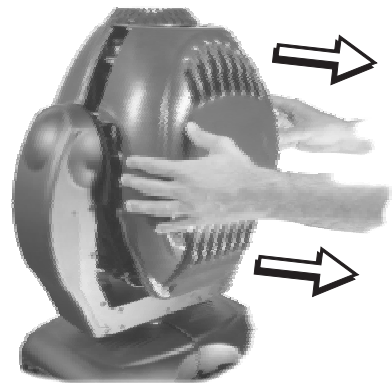

Photo 3

## 12- Replacing gobos

XR7 uses a mechanical system which allows the fixture's gobos to be removed without the use of specialist equipment. Replacement gobos should be made of either heat resistant glass or metal. An ever-increasing range of gobos is available from your DTS sales network.

Gobo dimensions are as follows:

ø external = 28 mm (or 27 mm from the back)

ø of image with defined edge = 24 mm

thickness = from 0.2 to 3.5 mm

### Replacing gobos on the rotating gobo wheel

When replacing gobos as shown in the following diagrams, ensure that the projector is not turned on.

- 1) Open the projector housing as described above.
- 2) Loosen the screws as shown (photo 1) and remove the metal leaf to allow easier access to the gobos.
- 3) Release the gobo retaining spring and carefully remove the gobo (photo 2-3).
- 4) Reverse the procedure to install a replacement gobo.



Photo 1



Photo 2

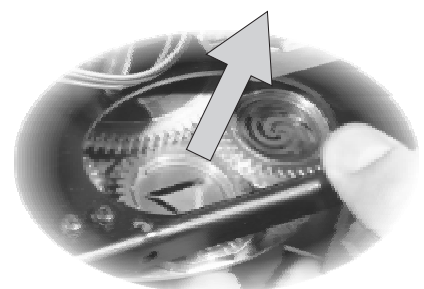

Photo 3

# Moving head projector



## 13 Periodic cleaning

### Lenses and reflectors

Even a fine layer of dust can reduce the luminous output substantially. Regularly clean all lenses and the reflector using a soft cotton cloth, dampened with a specialist lens cleaning solution.

### Fans and air passages

The fans and air passages must be cleaned approximately every 6 weeks. This periodic cleaning will depend of course, on the conditions in which the projector is operating. Suitable instruments for performing this type of maintenance are a brush and a common vacuum cleaner or an air compressor. If necessary, clean the fans and air passages more frequently.

## 13.1- Periodic controls

### Lamp

The lamp should be replaced if there is any visible damage or deformation due to heat. This will help to avoid the danger of the lamp exploding.

### Mechanical parts

Periodically check all mechanical parts gears, guides, belts, etc. for wear and tear, replacing them if necessary. Periodically check the lubrication of all components, particularly the parts subject to high temperatures. If necessary, lubricate with suitable lubricant, available from your D.T.S. distributor. Check the tension of the belts and adjust if necessary.

### Electrical components

Check all electrical components for correct earthing and proper attachment of all connectors, refastening if necessary.

### Fuse replacement

Locate the fuse, which protects the lamp and electronics, in the base of the XR7.

Using a multimeter, test the condition of the fuse, replacing it with one of equivalent type if necessary.

### Attention

Disconnect mains power prior to removing the projector housing.

# Moving head projector



## APPENDIX 2 8 MOTOR CARD

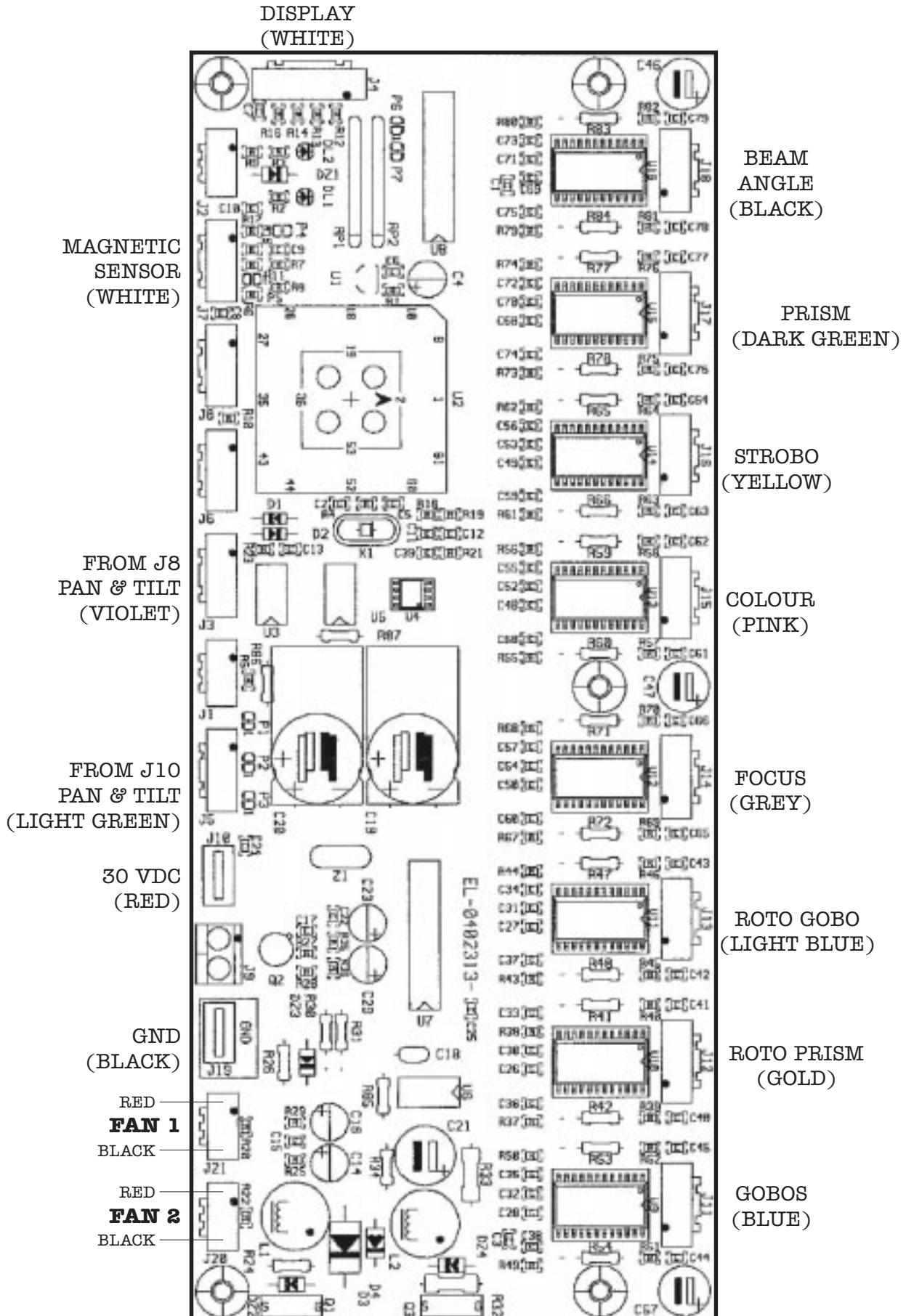

# Moving head projector

# XR7

GB

19

## PAN & TILT CARD

PAN  
(WHITE)

TILT  
(BROWN) GND  
(BLACK)

30 VDC FAN  
(RED) (WHITE)

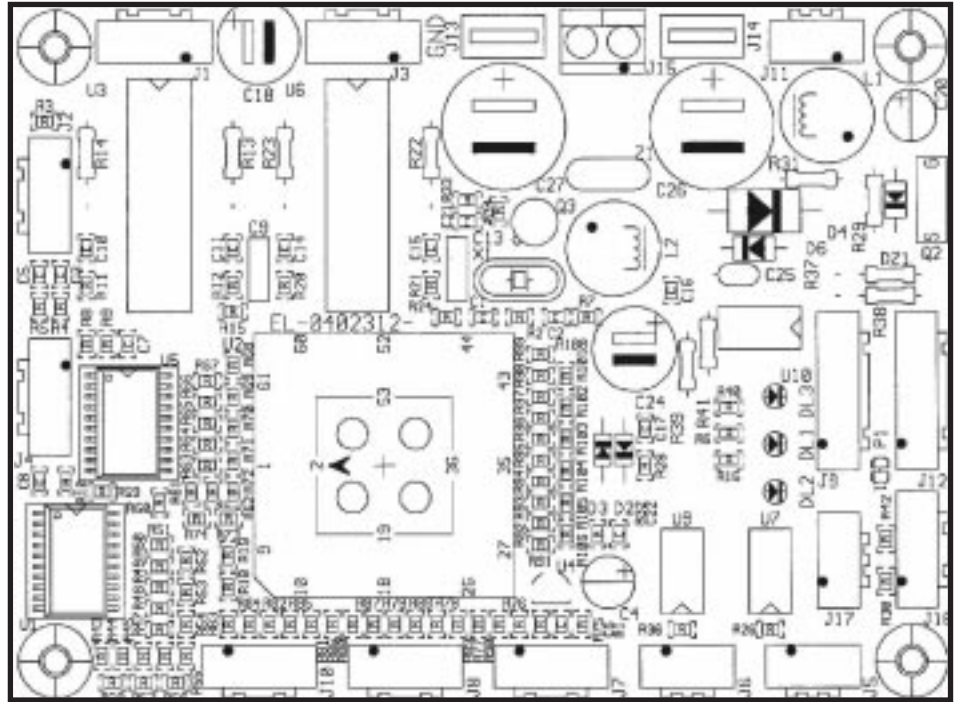

ENCODER PAN  
(RED)

ENCODER TILT  
(ORANGE)

DATA 1  
(VIOLET)  
DATA 2  
(LIGHT GREEN)  
MOTOR TILT  
(BROWN)

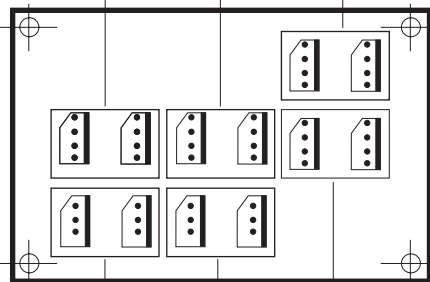

FROM J5 8 MOTORS  
(LIGHT GREEN)  
FROM J3 8 MOTORS  
(VIOLET)

DMX INPUT  
(WHITE)

## SENDING AGAIN CARD

### DISPLAY CARD

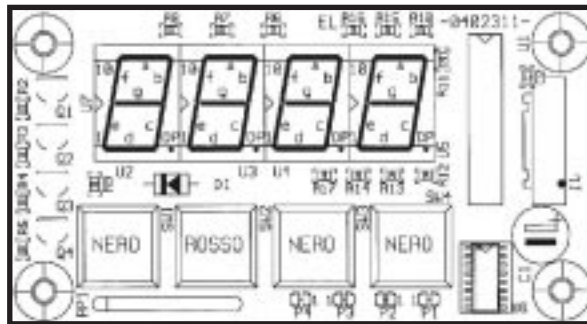

FROM J4  
8 MOTOR PCB

IN LAMP

OUT LAMP

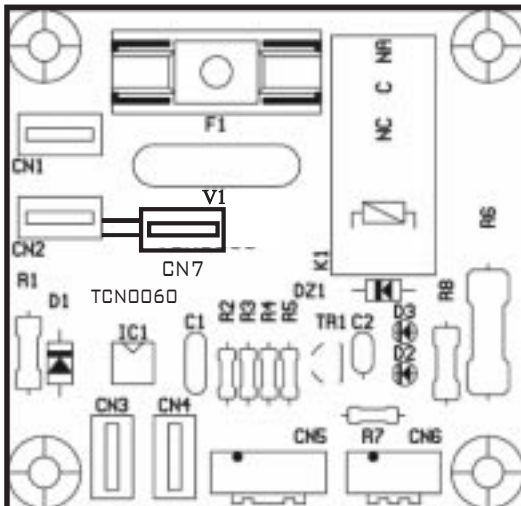

## ON / OFF LAMP CARD

If the PCB card doesn't work, move the cable "IN LAMP" from Cn1 to Cn7

To delete **SnEr** error from display, in

Menu **LAMP** select **off**

24V

FROM J16  
PAN & TILT  
CARD

FROM J7  
PAN & TILT  
CARD

# Moving head projector



## 8 CHANNELS MODE (8 CH)

|   |                              |
|---|------------------------------|
| 1 | ROTOGOBO                     |
| 2 | COLOUR                       |
| 3 | GOBO                         |
| 4 | SHUTTER                      |
| 5 | PAN                          |
| 6 | TILT                         |
| 7 | PRISM/ROTOPRISM              |
| 8 | FOCUS/LIGHT BEAM ANGLE/FROST |

## 10 CHANNELS MODE(10CH:default setting)

|    |                              |
|----|------------------------------|
| 1  | ROTOGOBO                     |
| 2  | COLOUR                       |
| 3  | GOBO                         |
| 4  | SHUTTER                      |
| 5  | PAN                          |
| 6  | TILT                         |
| 7  | PRISM/ROTOPRISM              |
| 8  | FOCUS/LIGHT BEAM ANGLE/FROST |
| 9  | PAN lsb                      |
| 10 | TILT lsb                     |

|             |   |                            |
|-------------|---|----------------------------|
| DMX CHANNEL | 1 | Parameter: <b>ROTOGOBO</b> |
|-------------|---|----------------------------|

| DMX range Value | Mid point DMX value | Move range (degrees) | Mode | Option | Function                     |
|-----------------|---------------------|----------------------|------|--------|------------------------------|
| 0-127           | 63                  |                      |      |        | Proportional from 0° to 360° |
| 128-180         | 154                 |                      |      |        | left rotation                |
| 181-202         | 191                 |                      |      |        | Stop                         |
| 203-255         | 229                 |                      |      |        | right rotation               |

|             |   |                          |
|-------------|---|--------------------------|
| DMX CHANNEL | 2 | Parameter: <b>COLOUR</b> |
|-------------|---|--------------------------|

| DMX range Value | Mid point DMX value | Move range (degrees) | Mode | Option | Function     |
|-----------------|---------------------|----------------------|------|--------|--------------|
| 0-10            | 5                   |                      |      |        | Colour1      |
| 11-21           | 16                  |                      |      |        | Bicolour ½   |
| 22-32           | 27                  |                      |      |        | Colour2      |
| 33-43           | 38                  |                      |      |        | Bicolour 2/3 |
| 44-54           | 49                  |                      |      |        | Colour3      |
| 55-65           | 60                  |                      |      |        | Bicolour 3/4 |
| 66-76           | 71                  |                      |      |        | Colour4      |
| 77-87           | 82                  |                      |      |        | Bicolour 4/5 |
| 88-98           | 93                  |                      |      |        | Colour5      |
| 99-109          | 104                 |                      |      |        | Bicolour 5/6 |
| 110-120         | 115                 |                      |      |        | Colour6      |
| 121-131         | 126                 |                      |      |        | Bicolour 6/7 |
| 132-142         | 137                 |                      |      |        | Colour7      |
| 143-153         | 148                 |                      |      |        | Bicolour 7/8 |
| 154-164         | 159                 |                      |      |        | Colour8      |

# Moving head projector



|         |     |  |  |  |                                    |
|---------|-----|--|--|--|------------------------------------|
| 165-175 | 170 |  |  |  | <b>Bicolour 8/9</b>                |
| 176-186 | 181 |  |  |  | <b>Colour9</b>                     |
| 187-197 | 192 |  |  |  | <b>Bicolour 9/1</b>                |
| 198-200 | 199 |  |  |  | <b>Right rotation speed 1 min.</b> |
| 201-203 | 202 |  |  |  | <b>Right rotation speed 2</b>      |
| 204-206 | 205 |  |  |  | <b>Right rotation speed 3</b>      |
| 207-209 | 208 |  |  |  | <b>Right rotation speed 4</b>      |
| 210-212 | 211 |  |  |  | <b>Right rotation speed 5</b>      |
| 213-215 | 214 |  |  |  | <b>Right rotation speed 6</b>      |
| 216-218 | 217 |  |  |  | <b>Right rotation speed 7</b>      |
| 219-221 | 220 |  |  |  | <b>Right rotation speed 8</b>      |
| 222-224 | 223 |  |  |  | <b>Right rotation speed 9 max.</b> |
| 225-228 | 226 |  |  |  | <b>Stop</b>                        |
| 229-231 | 230 |  |  |  | <b>Left rotation speed 1 min.</b>  |
| 232-234 | 233 |  |  |  | <b>Left rotation speed 2</b>       |
| 235-237 | 236 |  |  |  | <b>Left rotation speed 3</b>       |
| 238-240 | 239 |  |  |  | <b>Left rotation speed 4</b>       |
| 241-243 | 242 |  |  |  | <b>Left rotation speed 5</b>       |
| 244-246 | 245 |  |  |  | <b>Left rotation speed 6</b>       |
| 247-249 | 248 |  |  |  | <b>Left rotation speed 7</b>       |
| 250-252 | 251 |  |  |  | <b>Left rotation speed 8</b>       |
| 253-255 | 254 |  |  |  | <b>Left rotation speed 9 max.</b>  |

|             |   |                              |
|-------------|---|------------------------------|
| DMX CHANNEL | 3 | Parameter: <b>GOBO WHEEL</b> |
|-------------|---|------------------------------|

| DMX range Value | Mid point DMX value | Move range (degrees) | Mode | Option | Function                     |
|-----------------|---------------------|----------------------|------|--------|------------------------------|
| 0-25            | 12                  |                      |      |        | <b>Open</b>                  |
| 26-51           | 38                  |                      |      |        | <b>Gobo 1</b>                |
| 52-77           | 64                  |                      |      |        | <b>Gobo 2</b>                |
| 78-103          | 90                  |                      |      |        | <b>Gobo 3</b>                |
| 104-129         | 116                 |                      |      |        | <b>Gobo 4</b>                |
| 130-155         | 142                 |                      |      |        | <b>Gobo 5</b>                |
| 156-181         | 168                 |                      |      |        | <b>Gobo 6</b>                |
| 182-207         | 194                 |                      |      |        | <b>Gobo 7</b>                |
| 208-213         | 210                 |                      |      |        | <b>Rotation speed 1 min.</b> |
| 214-219         | 216                 |                      |      |        | <b>Rotation speed 2</b>      |
| 220-225         | 222                 |                      |      |        | <b>Rotation speed 3</b>      |
| 226-231         | 228                 |                      |      |        | <b>Rotation speed 4</b>      |
| 232-237         | 234                 |                      |      |        | <b>Rotation speed 5</b>      |
| 238-243         | 240                 |                      |      |        | <b>Rotation speed 6</b>      |
| 244-249         | 246                 |                      |      |        | <b>Rotation speed 7</b>      |
| 250-255         | 252                 |                      |      |        | <b>Rotation speed 8 max.</b> |

# Moving head projector



|             |          |                           |
|-------------|----------|---------------------------|
| DMX CHANNEL | <b>4</b> | Parameter: <b>SHUTTER</b> |
|-------------|----------|---------------------------|

| DMX range Value | Mid point DMX value | Move range (degrees) | Mode | Option | Function                                 |
|-----------------|---------------------|----------------------|------|--------|--|
| <b>0-9</b>      | <b>4</b>            |                      |      |        | <b>Black out</b>                         |
| <b>10-85</b>    | <b>47</b>           |                      |      |        | <b>Dimmer</b>                            |
| <b>86-95</b>    | <b>90</b>           |                      |      |        | <b>Strobo random speed</b>               |
| <b>96-105</b>   | <b>100</b>          |                      |      |        | <b>Strobo speed 1 min.</b>               |
| <b>106-115</b>  | <b>110</b>          |                      |      |        | <b>Strobo speed 2</b>                    |
| <b>116-125</b>  | <b>120</b>          |                      |      |        | <b>Strobo speed 3</b>                    |
| <b>126-135</b>  | <b>130</b>          |                      |      |        | <b>Strobo speed 4</b>                    |
| <b>136-145</b>  | <b>140</b>          |                      |      |        | <b>Strobo speed 5</b>                    |
| <b>146-155</b>  | <b>150</b>          |                      |      |        | <b>Strobo speed 6 max.</b>               |
| <b>156-165</b>  | <b>160</b>          |                      |      |        | <b>Pulse open speed 1 min.</b>           |
| <b>166-175</b>  | <b>170</b>          |                      |      |        | <b>Pulse open speed 2</b>                |
| <b>176-185</b>  | <b>180</b>          |                      |      |        | <b>Pulse open speed 3</b>                |
| <b>186-195</b>  | <b>190</b>          |                      |      |        | <b>Pulse open speed 4 max</b>            |
| <b>196-205</b>  | <b>200</b>          |                      |      |        | <b>Pulse closed speed 1 min.</b>         |
| <b>206-215</b>  | <b>210</b>          |                      |      |        | <b>Pulse closed speed 2</b>              |
| <b>216-225</b>  | <b>220</b>          |                      |      |        | <b>Pulse closed speed 3</b>              |
| <b>226-235</b>  | <b>230</b>          |                      |      |        | <b>Pulse closed speed 4 max.</b>         |
| <b>236-245</b>  | <b>240</b>          |                      |      |        | <b>Colour/gobo/pan/tilt in black out</b> |
| <b>246-255</b>  | <b>250</b>          |                      |      |        | <b>Open</b>                              |

|             |          |                           |
|-------------|----------|---------------------------|
| DMX CHANNEL | <b>5</b> | Parameter: <b>PAN msb</b> |
|-------------|----------|---------------------------|

|             |          |                            |
|-------------|----------|----------------------------|
| DMX CHANNEL | <b>6</b> | Parameter: <b>TILT msb</b> |
|-------------|----------|----------------------------|

|             |          |                                   |
|-------------|----------|-----------------------------------|
| DMX CHANNEL | <b>7</b> | Parameter: <b>PRISM/ROTOPRISM</b> |
|-------------|----------|-----------------------------------|

| DMX range Value | Mid point DMX value | Move range (degrees) | Mode | Option | Function              |
|-----------------|---------------------|----------------------|------|--------|-----------------------|
| <b>0-63</b>     | <b>31</b>           |                      |      |        | <b>No effect</b>      |
| <b>64-145</b>   | <b>104</b>          |                      |      |        | <b>Prism</b>          |
| <b>128-191</b>  | <b>159</b>          |                      |      |        | <b>Left rotation</b>  |
| <b>192-255</b>  | <b>223</b>          |                      |      |        | <b>Right rotation</b> |

|             |          |  |
|-------------|----------|--|
| DMX CHANNEL | <b>8</b> | Parameter: <b>FOCUS/LIGHT BEAM ANGLE/FROST</b> |
|-------------|----------|--|

| DMX range Value | Mid point DMX value | Move range (degrees) | Mode | Option | Function |
|-----------------|---------------------|----------------------|------|--------|----------|
|-----------------|---------------------|----------------------|------|--------|----------|

# Moving head projector



|         |     |  |  |  |                 |
|---------|-----|--|--|--|-----------------|
| 0-72    | 36  |  |  |  | No lens 13°     |
| 73-145  | 109 |  |  |  | First lens 18°  |
| 146-218 | 182 |  |  |  | Second lens 21° |
| 219-255 | 237 |  |  |  | frost           |

|             |   |                           |
|-------------|---|---------------------------|
| DMX CHANNEL | 9 | Parameter: <b>PAN lsb</b> |
|-------------|---|---------------------------|

|             |    |                            |
|-------------|----|----------------------------|
| DMX CHANNEL | 10 | Parameter: <b>TILT lsb</b> |
|-------------|----|----------------------------|

## 16 CHANNELS MODE (16CH)

- 1 PAN msb
- 2 PAN lsb
- 3 TILT msb
- 4 TILT lsb
- 5 SPEED MOVEMENT
- 6 DIMMER
- 7 SHUTTER
- 8 COLOUR
- 9 COLOUR PROPORTIONAL (Priority on Colour)
- 10 GOBO
- 11 ROTOGOBO
- 12 PRISM/ROTOPRISM
- 13 FOCUS
- 14 LIGHT BEAM ANGLE
- 15 FROST (Priority)
- 16 RESET + LAMP

|             |   |                           |
|-------------|---|---------------------------|
| DMX CHANNEL | 1 | Parameter: <b>PAN msb</b> |
|-------------|---|---------------------------|

|             |   |                           |
|-------------|---|---------------------------|
| DMX CHANNEL | 2 | Parameter: <b>PAN lsb</b> |
|-------------|---|---------------------------|

|             |   |                            |
|-------------|---|----------------------------|
| DMX CHANNEL | 3 | Parameter: <b>TILT msb</b> |
|-------------|---|----------------------------|

|             |   |                            |
|-------------|---|----------------------------|
| DMX CHANNEL | 4 | Parameter: <b>TILT lsb</b> |
|-------------|---|----------------------------|

|             |   |                                  |
|-------------|---|----------------------------------|
| DMX CHANNEL | 5 | Parameter: <b>MOVEMENT SPEED</b> |
|-------------|---|----------------------------------|

| DMX range<br>Value | Mid point<br>DMX value | Move<br>range<br>(degrees) | Mode | Option | Function  |
|--------------------|------------------------|----------------------------|------|--------|---|
| 0-10               | 5                      |                            |      |        | <b>Standard</b>   |
| 11-25              | 18                     |                            |      |        | <b>Fast movement</b>                                      |
| 26-127             | 76                     |                            |      |        | <b>Vector mode from fast<br/>to slow</b>                  |
| 128-247            | 187                    |                            |      |        | <b>Variable time reaction<br/>to DMX signal ( fast to</b> |

# Moving head projector



|         |     |  |  |  |   |
|---------|-----|--|--|--|---|
|         |     |  |  |  | <b>slow)</b>                            |
| 248-255 | 251 |  |  |  | <b>Slow reaction time to DMX signal</b> |

|             |   |                          |
|-------------|---|--------------------------|
| DMX CHANNEL | 6 | Parameter: <b>DIMMER</b> |
|-------------|---|--------------------------|

| DMX range Value | Mid point DMX value | Move range (degrees) | Mode | Option | Function                   |
|-----------------|---------------------|----------------------|------|--------|----------------------------|
| 0-8             | 4                   |                      |      |        | <b>Black-out</b>           |
| 9-255           |                     |                      |      |        | <b>Proportional dimmer</b> |

|             |   |                           |
|-------------|---|---------------------------|
| DMX CHANNEL | 7 | Parameter: <b>SHUTTER</b> |
|-------------|---|---------------------------|

| DMX range Value | Mid point DMX value | Move range (degrees) | Mode | Option | Function                            |
|-----------------|---------------------|----------------------|------|--------|-------------------------------------|
| 0-9             | 5                   |                      |      |        | <b>Black-out</b>                    |
| 10-23           | 16                  |                      |      |        | <b>Strobo random speed</b>          |
| 24-37           | 30                  |                      |      |        | <b>Strobo speed 1 min.</b>          |
| 38-51           | 44                  |                      |      |        | <b>Strobo speed 2</b>               |
| 52-65           | 58                  |                      |      |        | <b>Strobo speed 3</b>               |
| 66-79           | 72                  |                      |      |        | <b>Strobo speed 4</b>               |
| 80-93           | 86                  |                      |      |        | <b>Strobo speed 5</b>               |
| 94-107          | 100                 |                      |      |        | <b>Strobo speed 6 max.</b>          |
| 108-121         | 114                 |                      |      |        | <b>Pulse open speed 1 min.</b>      |
| 122-135         | 128                 |                      |      |        | <b>Pulse open speed 2</b>           |
| 136-149         | 142                 |                      |      |        | <b>Pulse open speed 3</b>           |
| 150-163         | 156                 |                      |      |        | <b>Pulse open speed 4 max.</b>      |
| 164-177         | 170                 |                      |      |        | <b>Pulse closed speed 1 min.</b>    |
| 178-191         | 184                 |                      |      |        | <b>Pulse closed speed 2</b>         |
| 192-205         | 198                 |                      |      |        | <b>Pulse closed speed 3</b>         |
| 206-219         | 212                 |                      |      |        | <b>Pulse closed speed 4 max.</b>    |
| 220-227         | 225                 |                      |      |        | <b>Colour and Gobo in black-out</b> |
| 228-233         | 230                 |                      |      |        | <b>Pan and Tilt in black-out</b>    |
| 234-255         | 244                 |                      |      |        | <b>Open</b>                         |

|             |   |                          |
|-------------|---|--------------------------|
| DMX CHANNEL | 8 | Parameter: <b>COLOUR</b> |
|-------------|---|--------------------------|

| DMX range Value | Mid point DMX value | Move range (degrees) | Mode | Option | Function            |
|-----------------|---------------------|----------------------|------|--------|---------------------|
| 0-10            | 5                   |                      |      |        | <b>Colour1</b>      |
| 11-21           | 16                  |                      |      |        | <b>Bicolour ½</b>   |
| 22-32           | 27                  |                      |      |        | <b>Colour2</b>      |
| 33-43           | 38                  |                      |      |        | <b>Bicolour 2/3</b> |

# Moving head projector



|         |     |  |  |  |                                    |
|---------|-----|--|--|--|------------------------------------|
| 44-54   | 49  |  |  |  | <b>Colour3</b>                     |
| 55-65   | 60  |  |  |  | <b>Bicolour 3/4</b>                |
| 66-76   | 71  |  |  |  | <b>Colour4</b>                     |
| 77-87   | 82  |  |  |  | <b>Bicolour 4/5</b>                |
| 88-98   | 93  |  |  |  | <b>Colour5</b>                     |
| 99-109  | 104 |  |  |  | <b>Bicolour 5/6</b>                |
| 110-120 | 115 |  |  |  | <b>Colour6</b>                     |
| 121-131 | 126 |  |  |  | <b>Bicolour 6/7</b>                |
| 132-142 | 137 |  |  |  | <b>Colour7</b>                     |
| 143-153 | 148 |  |  |  | <b>Bicolour 7/8</b>                |
| 154-164 | 159 |  |  |  | <b>Colour8</b>                     |
| 165-175 | 170 |  |  |  | <b>Bicolour 8/9</b>                |
| 176-186 | 181 |  |  |  | <b>Colour9</b>                     |
| 187-197 | 192 |  |  |  | <b>Bicolour 9/1</b>                |
| 198-200 | 199 |  |  |  | <b>Right rotation speed 1 min.</b> |
| 201-203 | 200 |  |  |  | <b>Right rotation speed 2</b>      |
| 204-206 | 205 |  |  |  | <b>Right rotation speed 3</b>      |
| 207-209 | 208 |  |  |  | <b>Right rotation speed 4</b>      |
| 210-212 | 211 |  |  |  | <b>Right rotation speed 5</b>      |
| 213-215 | 214 |  |  |  | <b>Right rotation speed 6</b>      |
| 216-218 | 217 |  |  |  | <b>Right rotation speed 7</b>      |
| 219-221 | 220 |  |  |  | <b>Right rotation speed 8</b>      |
| 222-224 | 223 |  |  |  | <b>Right rotation speed 9 max.</b> |
| 225-228 | 226 |  |  |  | <b>Stop</b>                        |
| 229-231 | 230 |  |  |  | <b>Left rotation speed 1 min.</b>  |
| 232-234 | 233 |  |  |  | <b>Left rotation speed 2</b>       |
| 235-237 | 236 |  |  |  | <b>Left rotation speed 3</b>       |
| 238-240 | 239 |  |  |  | <b>Left rotation speed 4</b>       |
| 241-243 | 242 |  |  |  | <b>Left rotation speed 5</b>       |
| 244-246 | 245 |  |  |  | <b>Left rotation speed 6</b>       |
| 247-249 | 248 |  |  |  | <b>Left rotation speed 7</b>       |
| 250-252 | 251 |  |  |  | <b>Left rotation speed 8</b>       |
| 253-255 | 254 |  |  |  | <b>Left rotation speed 9 max.</b>  |

|             |   |  |
|-------------|---|--|
| DMX CHANNEL | 9 | Parameter: <b>PROPORTIONAL COLOUR (PRIORITY)</b> |
|-------------|---|--|

| DMX range Value | Mid point DMX value | Move range (degrees) | Mode | Option | Function            |
|-----------------|---------------------|----------------------|------|--------|---------------------|
| 0-10            | 5                   |                      |      |        | No effect           |
| 11-255          |                     |                      |      |        | Proportional colour |

|             |    |                        |
|-------------|----|------------------------|
| DMX CHANNEL | 10 | Parameter: <b>GOBO</b> |
|-------------|----|------------------------|

| DMX range Value | Mid point DMX value | Move range (degrees) | Mode | Option | Function |
|-----------------|---------------------|----------------------|------|--------|----------|
| 0-25            | 12                  |                      |      |        | Open     |

# Moving head projector



|         |     |  |  |  |                       |
|---------|-----|--|--|--|-----------------------|
| 26-51   | 38  |  |  |  | Gobo 1                |
| 52-77   | 64  |  |  |  | Gobo 2                |
| 78-103  | 90  |  |  |  | Gobo 3                |
| 104-129 | 116 |  |  |  | Gobo 4                |
| 130-155 | 142 |  |  |  | Gobo 5                |
| 156-181 | 168 |  |  |  | Gobo 6                |
| 182-207 | 194 |  |  |  | Gobo 7                |
| 208-213 | 210 |  |  |  | Speed rotation 1 min. |
| 214-219 | 216 |  |  |  | Speed rotation 2      |
| 220-225 | 222 |  |  |  | Speed rotation 3      |
| 226-231 | 228 |  |  |  | Speed rotation 4      |
| 232-237 | 234 |  |  |  | Speed rotation 5      |
| 238-243 | 240 |  |  |  | Speed rotation 6      |
| 244-249 | 246 |  |  |  | Speed rotation 7      |
| 250-255 | 252 |  |  |  | Speed rotation 8 max. |

|             |    |                             |
|-------------|----|-----------------------------|
| DMX CHANNEL | 11 | Parameter: <b>ROTO GOBO</b> |
|-------------|----|-----------------------------|

| DMX range Value | Mid point DMX value | Move range (degrees) | Mode | Option | Function                     |
|-----------------|---------------------|----------------------|------|--------|------------------------------|
| 0-127           |                     |                      |      |        | Proportional from 0° to 360° |
| 128-180         |                     |                      |      |        | Left rotation                |
| 181-202         | 191                 |                      |      |        | Stop                         |
| 203-255         |                     |                      |      |        | Right rotation               |

|             |    |                                   |
|-------------|----|-----------------------------------|
| DMX CHANNEL | 12 | Parameter: <b>PRISM/ROTOPRISM</b> |
|-------------|----|-----------------------------------|

| DMX range Value | Mid point DMX value | Move range (degrees) | Mode | Option | Function       |
|-----------------|---------------------|----------------------|------|--------|----------------|
| 0-63            | 32                  |                      |      |        | No effect      |
| 64-127          | 95                  |                      |      |        | Prism          |
| 128-191         |                     |                      |      |        | Left rotation  |
| 192-255         |                     |                      |      |        | Right rotation |

|             |    |                         |
|-------------|----|-------------------------|
| DMX CHANNEL | 13 | Parameter: <b>FOCUS</b> |
|-------------|----|-------------------------|

| DMX range Value | Mid point DMX value | Move range (degrees) | Mode | Option | Function     |
|-----------------|---------------------|----------------------|------|--------|--------------|
| 0-255           |                     |                      |      |        | proportional |

|             |    |                                    |
|-------------|----|------------------------------------|
| DMX CHANNEL | 14 | Parameter: <b>LIGHT BEAM ANGLE</b> |
|-------------|----|------------------------------------|

| DMX range | Mid point | Move | Mode | Option | Function |
|-----------|-----------|------|------|--------|----------|
|-----------|-----------|------|------|--------|----------|

# Moving head projector



| Value          | DMX value  | range (degrees) |  |  |                        |
|----------------|------------|-----------------|--|--|------------------------|
| <b>0-84</b>    | <b>42</b>  |                 |  |  | <b>No lens 13°</b>     |
| <b>85-170</b>  | <b>127</b> |                 |  |  | <b>First lens 18°</b>  |
| <b>171-255</b> | <b>213</b> |                 |  |  | <b>Second lens 21°</b> |

|             |           |                                    |
|-------------|-----------|------------------------------------|
| DMX CHANNEL | <b>15</b> | Parameter: <b>FROST (PRIORITY)</b> |
|-------------|-----------|------------------------------------|

| DMX range Value | Mid point DMX value | Move range (degrees) | Mode | Option | Function       |
|-----------------|---------------------|----------------------|------|--------|----------------|
| <b>0-127</b>    | <b>63</b>           |                      |      |        | <b>No lens</b> |
| <b>128-255</b>  | <b>191</b>          |                      |      |        | <b>Frost</b>   |

|             |           |                         |
|-------------|-----------|-------------------------|
| DMX CHANNEL | <b>16</b> | Parameter: <b>RESET</b> |
|-------------|-----------|-------------------------|

| DMX range Value | Mid point DMX value | Move range (degrees) | Mode | Option | Function                                    |
|-----------------|---------------------|----------------------|------|--------|---|
| <b>0-29</b>     |                     |                      |      |        | <b>No effect</b>                            |
| <b>30-85</b>    |                     |                      |      |        | <b>Lamp OFF</b> (activated after 3 seconds) |
| <b>86 - 170</b> |                     |                      |      |        | <b>Internal motor Reset</b>                 |
| <b>171-235</b>  |                     |                      |      |        | <b>Total Reset</b>                          |
| <b>236-255</b>  |                     |                      |      |        | <b>Lamp ON</b> (activated after 3 seconds)  |