Document Data Sheet

C21/EC21 Series Dimmer Rack Operator's Guide

Strand Lighting Part #: 2-450174-010
Bound Part Number:
Boxed Part Number:
Current Revision Level: 1d0
Written By: Charles Coley, II
Original Release Date: October 2005
Current Revision By: Charles Coley, II
Current Revision Date: 02/17/06

Revision History

Issue	Date	Reason
1a0	11/02/05	Rough Draft
1b0	01/06/06	Graphics added for menus. More text added.
1d0	02/17/06	Revised graphics

Notes

This document is generated on Microsoft Word for Windows 2000, and is formatted for two-sided reproduction.

All blank pages are on purpose.

Printer/Font Data

This document requires Windows 3.1 or later and TrueType fonts.

Variables

The name of the product is taken from the Document Properties sheet Subject field.

Controller name: C21/EC21 Dimmer Rack

Additional document properties defined:

Project: C21/EC21 series dimmer rack

Date completed: 02/17/06

Document number: 2-450174-010

version: 1d0

Archive Data





Operator's Guide

C21
EC21

Dimmer Rack

C21 Manual Part Number: 2-450174-010
EC21 Manual Part Number: 2-450174-020
Revision Level: 1d0
Revision Date: 17-February-2006
Written By: Charles Coley, II

The material in this manual is for information purposes only and is subject to change without notice. Strand Lighting assumes no responsibility for any errors or omissions, which may appear in this manual. For comments and suggestions regarding corrections and/or updates to this manual, please contact the nearest Strand Lighting office.

El contenido de este manual es solamente para información y está sujeto a cambios sin previo aviso. Strand Lighting no asume responsabilidad por errores o omisiones que puedan aparecer. Cualquier comentario, sugerencia o corrección con respecto a este manual, favor de dirigirlo a la oficina de Strand Lighting más cercana.

Der Inhalt dieses Handbuches ist nur für Informationszwecke gedacht, Aenderungen sind vorbehalten. Strand Lighting uebernimmt keine Verantwortung für Fehler oder Irrtuemer, die in diesem Handbuch auftreten. Für Bemerkungen und Verbesserungsvorschlaege oder Vorschlaege in Bezug auf Korrekturen und/oder Aktualisierungen in diesem Handbuch, moechten wir Sie bitten, Kontakt mit der naechsten Strand Lighting-Niederlassung aufzunehmen.

Le matériel décrit dans ce manuel est pour information seulement et est sujet à changements sans préavis. La compagnie Strand Lighting n'assume aucune responsabilité sur toute erreur ou omission inscrite dans ce manuel. Pour tous commentaires ou suggestions concernant des corrections et/ou les mises à jour de ce manuel, veuillez s'il vous plait contacter le bureau de Strand Lighting le plus proche.

Copyright 2006, Strand Lighting. All rights reserved.

Information contained in this document may not be duplicated in full or in part by any person without prior written approval of Strand Lighting Ltd. Its sole purpose is to provide the user with detailed installation information for the equipment supplied. The use of this document for all other purposes is specifically prohibited.

Prefix

Thank you for choosing Strand Lighting C21/EC21 series dimmer rack. We trust that the equipment will meet all your dimming needs and will provide you with reliable service for many years.

Strand Lighting can assure you that every effort has been made to ensure that the equipment has been designed to meet the highest professional standards and that dimmer racks and their components have been assembled, inspected, and tested in accordance with our strict quality assurance program.

Should you encounter any problems or difficulties with your dimmer racks, please contact the nearest Strand Lighting service representative. For a complete list of Strand Lighting offices and service centers or visit our Web site (www.strandlighting.com).

This manual describes the operation of for C21/EC21 series dimmer racks. A separate Installation Guide provided with the dimmer racks describes how to install the dimmer racks and perform initial setup procedures.

Strand Lighting Offices:

United States: 6603 Darin Way, Cypress, CA 90630
Tel: 001-714-230-8200 Fax: 001-714-899-0042

Canada: 2430 Lucknow Drive #15, Mississauga, Ontario L5S 1V3, Canada
Tel: 001-905-677-7130 Fax: 001-905-677-6859

Asia: 20F, Delta House, 3 on Yin Street, Shatin, N.T. Hong Kong ROC.
Tel: 008-522-757-3033 Fax: 008-522-757-1767

Scotland: Mitchelston Industrial Estate, Kirkcaldy, Fife, KY1 3LY, Scotland
Tel: 01592-652333 Fax: 01592-653528

United Kingdom: Unit 3 Hammersmith Studios, Yeldhan Road, Hammersmith, London W6 8JF, United Kingdom
Tel: +44 (0) 1592-656-400 Fax: +44 (0) 20-8735-9799

Italy: Via delle Gardenie, 33, 00040 Pomezia – Roma, Italy
Tel: 00-39-06-919-631 Fax: 00-39-06-914-7136

Germany: Kurfürstendamm 70, 10709, Berlin, Germany
Tel: 00-49-30-707-9510 Fax: 00-49-30-707-95199

Definition of Terms

This manual uses the following terms throughout:

channel	A device controlling a dimmer or group of dimmers. Historically, there is a physical controller (such as a slider) for each channel. On most current control systems, channels are numbers accessed by a numeric keypad. Each channel can control multiple dimmers.
circuit	A connection device and wiring for powering a lighting fixture from a dimmer.
circuit ID	A unique four-digit numeric identity which you can assign to each dimmer. The circuit ID may be the same as the dimmer number, or may be a number used to indicate circuit location, phase, channel number, etc. This feature is useful for system wide control functions.
crossfade	A fade that contains both an up-fade and a down-fade, or any fade where the levels of one cue are replaced by the levels of another cue.
cue	The process of recalling a preset from its memory location and putting the result on stage. Preset, Memory, and cue are often used interchangeably.
curve	The relationship between a control level and the actual dimmer output.
dimmer	A device controlling power to a lighting fixture. Two lights on the same dimmer cannot be separately controlled.
default	The original factory settings.
DMX512	An ANSI communications protocol standard that describes a method of digital data transmission between controllers, lighting equipment and accessories.
Ethernet	A high-speed network based protocol used to transmit data from a lighting controller to a dimmer rack using a single Ethernet cable.
fade	A gradual change in stage levels from one set of intensities (“look”) to another.
fade time	The time it takes for dimmer levels to go from their current levels to the levels in the selected preset, or DMX value. Each preset has its own fade time.
level	A numerical value used to express the “brightness” of the load on a dimmer. Usually shown as %.
Outlook	A digital architectural control system for use with C21/EC21 dimmer racks.
patch	Historically, the process of physically connecting circuits to dimmers. Now usually refers to electronic assignment of dimmers to channels.
phase	The three phases of the mains supply to which the dimmers are connected are identified as Line 1, Line 2, Line 3 in 230v markets and as phase A, phase B, and phase C in 120v markets.
power module	A chassis containing one, two or four dimmer or contactors. This is sometimes referred to as a “dimmer”. However, each C21/EC21 power module can have multiple dimmers or contactors in it, so this manual distinguishes between dimmers (individual power control circuits) and power modules (a collection of one or more power control circuits).

preset	A pre-defined setup of intensities for a set of channels, stored in memory for later replay. For Outlook applications, the C21/EC21 series dimmer rack processor module stores 8 programmable presets per room for up to 16 rooms. For SWC applications, the processor module stores 128 programmable presets. Preset 0 (ZERO) is always a blackout.
Preset fade time	See "Fade Time".
profile	The relationship between a control level and the actual dimmer output. Also known as 'dimmer law' or 'curve'.
rack number	A number used to uniquely identify each dimmer rack in a multiple rack system. Rack numbers are set from the front panel of the rack processor module, and are usually set by the installation engineer.
room	An area separately defined for purposes of architectural lighting control (e.g., Outlook control stations). This is usually a room in the traditional sense (an indoor enclosed area) or a portion of a room that can be partitioned off. Each room may be separately and simultaneously controlled by the system.
RPH	Rack Processor Housing
RPM	Rack Processor Module
SSR	(Solid State relay) A power control device used in Strand dimmers that contains two silicon control rectifiers (SCRs), control circuitry, and optical isolation circuitry.
SWC	(System Wide Control) A method of programming and controlling more than one dimmer rack simultaneously. A hand held controller lets you program and recall 128 presets, and control individual dimmers. 8 and 16 channel pushbutton stations, and an A/V interface let you recall and 8 or 16 of the 128 presets at each station. Please contact Strand Lighting or see the <i>System Wide Control Data Sheet</i> or <i>System Wide Control User's Manual</i> for details on how SWC works.
Technical Assistance	C21/EC21 racks and dimmers require a minimum of maintenance and servicing. For operation or technical assistance, please contact Strand Lighting or the local Authorized Service Center serving your area. (www.strandlighting.com)

Contents

This manual describes the operation and setup of the dimmer rack. It does not contain information about installing the rack. See the separate *C21 (2-450173-010) or the EC21 (2-450173-020) Dimmer Rack Installation Manual* for detailed information concerning installation and wiring of the dimmer rack, then go to *Section 3 - Programming the C21/EC21 Dimmer Rack* starting on page 19 in this manual for initial rack setup and, if necessary, see *Section 4 - Basic Troubleshooting* starting on page 54 of this manual.

Section 1 - General	3
Summary Specification.....	3
120V Dimmer Modules.....	5
230V Dimmer Modules.....	7
Rack Components.....	10
Rack Processor Module	13
Power Supplies	13
Control Interconnection Card (CIC).....	13
LED Status	14
Section 2 - Operational Features.....	16
Rack Configuration.....	16
Dimmer Configuration	16
Safety Features.....	17
System Wide Control (SWC).....	18
Outlook.....	18
Section 3 - Programming the C21/EC21 Dimmer Rack	19
Controls and Displays	19
Key Lock	19
Using the Menu Keypad.....	20
The Status Log.....	20
The Main Menu	21
Rack Identity Menu.....	22
Network Config Menu.....	24
Rack Config menu.....	26
User Profile Menu.....	29
Dimmer Config Menu	30
Input Config Menu.....	37
SWC Menu.....	41
Outlook Menu.....	43
Local Control Menu	44
Status Reporting Menu.....	46
Factory Menu	48
Section 4 - Basic Troubleshooting.....	54
General	54
Control Signal Flow	54

Table of Figures

Figure 1 – C21/EC21 Series Dimmer Rack Fully Populated (doors removed).....	10
Figure 2 – Dual Dimmer Module	11
Figure 3 – Fan Housing	12
Figure 4 – Rack Processor Housing	12
Figure 5 – Rack Processor Module	13
Figure 6 - Processor Module Front Panel	14
Figure 7 - Rack Processor Module Front Panel	19
Figure 8 - Control Signal Flow.....	54

Section 1 - General

Summary Specification

Dimmer Rack Specifications:

Capacity:	Large rack: 48 Dimmer Modules (dual, single or quad) Mid-range rack: 36 Dimmer Modules (dual, single or quad) Small rack: 24 Dimmer Modules (dual, single or quad)
Supply:	90 to 264VAC, 3-phase, neutral + earth (Delta on request), 47 to 63 Hz
Max Current (per phase):	Large rack: 800 amps (120V markets), 600 amps (230V markets) Mid-range rack: 800 amps (120V markets), 600 amps (230V markets) small rack: 800 amps (120V markets), 600 amps (230V markets)
Dimensions:	Large rack: Height 80" (2032mm), Width 24.36" (619mm), Depth, 23.62" (600mm) Mid-range rack: Height 67" (1703mm), Width 24.36" (619mm), Depth, 23.62" (600mm) Small rack: Height 57" (1448mm), Width 24.36" (619mm), Depth, 23.62" (600mm)
Weight:	Large rack: 300 lbs. (136 Kg) empty and 690 lbs. (310 Kg) with all modules and electronics installed. Mid-range rack: 270 lbs. (122Kg) empty and 662 lbs. (300Kg) with all modules and electronics installed Small rack: 240 lbs. (109Kg) empty and 512 lbs. (232Kg) with all modules and electronics installed.
Busbar Rating:	50,000 AIC standard or 100,000 AIC optional
Control Circuit Isolation:	Optical isolation between high voltage and control electronics is 2500VAC. Control inputs are also isolated from the processor at 2500VAC, offering double optical isolation between the controller and high power circuits.
Storage Temp:	-40°C to 70°C
Operating Temp:	0°C to 40°C ambient
Storage Humidity:	0% to 95%, relative humidity, non-condensing
Operating Humidity:	10% to 95%, relative humidity, non-condensing

Note: All specifications are correct at the time of going to press. In the interest of continuous product improvement Strand Lighting reserves the right to change specifications without notice.

Dimmer Modules Specifications:

RCD (GFCI):	Residual Current Device with circuit protection.
Circuit protection:	Appropriately sized fully magnetic or thermal/magnetic circuit breaker of 10,000 AIC (15A, 20A, 50A & 100A @ 120V) or 50,000 AIC (15A, 25A & 50A @ 230V) fault current rating.
Output voltage:	Maximum full load voltage loss measured at the dimmer rack is 3 volts. Maximum output voltage for each dimmer can be limited through a software setting.
Load regulation:	Dimmers will maintain their output within +/- 1% of the set output with load changes from 1kW to the maximum rating of the dimmer.
Line compensation:	The system regulates dimmer outputs to within 1V over operating voltage range. Each dimmer is individually regulated.
Efficiency:	Minimum power efficiency for dimmers is 97% at full load. Maximum full load dimmer loss is 3V RMS. Contactor non-dim power efficiency is 99%.
DC component of output:	Less than 1 volt with tungsten loads from 60W to the maximum rating of the dimmer, at all control levels.
Input response time:	The response time (time between OFF and 100%) can be set to 'Fast' (30msec), 'Medium' (100ms), or 'Slow' (300ms). The default is medium (100ms).

Note: All specifications are correct at the time of going to press. In the interest of continuous product improvement Strand Lighting reserves the right to change specifications without notice.

120V Dimmer Modules The following dimmer & non-dim modules are currently available for the 120V markets:

Catalog #	Ampacity	Kw	Type	Reporting	Number of Chans	Load	Module Type
76550	10A	1.2kW	Basic	No	Quad	Incan.	2
76551	15A	1.8kW	Basic	No	Dual	Incan.	36
76552	15A	1.8kW	Standard	No	Dual	Incan.	36
76553	15A	1.8kW	Hi Rise	No	Dual	Incan.	36
76554	15A	1.8kW	Constant	No	Dual	Incan.	42
76555	15A	1.8kW	Nondim	No	Dual	Incan.	39
76556	15A	1.8kW	Basic	Yes	Dual	Incan.	15
76556-LED	15A	1.8kW	Basic	Yes	Dual	Incan.	15
76557	15A	1.8kW	Standard	Yes	Dual	Incan.	15
76557-LED	15A	1.8kW	Standard	Yes	Dual	Incan.	15
76558	15A	1.8kW	Hi Rise	Yes	Dual	Incan.	15
76558-LED	15A	1.8kW	Hi Rise	Yes	Dual	Incan.	15
76559	15A	1.8kW	Constant	Yes	Dual	Incan.	42
76560	15A	1.8kW	Nondim	Yes	Dual	Incan.	39
76560-LED	15A	1.8kW	Nondim	Yes	Dual	Incan.	39
76561	15A	1.8kW	Sinewave	Yes	Dual	Incan.	45
76562	20A	2.4kW	Basic	No	Dual	Incan.	53
76563	20A	2.4kW	Standard	No	Dual	Incan.	53
76564	20A	2.4kW	Hi Rise	No	Dual	Incan.	53
76565	20A	2.4kW	Constant	No	Dual	Incan.	59
76566	20A	2.4kW	Nondim	No	Dual	Incan.	56
76567	20A	2.4kW	Basic	Yes	Dual	Incan.	53
76567-LED	20A	2.4kW	Basic	Yes	Dual	Incan.	53
76568	20A	2.4kW	Standard	Yes	Dual	Incan.	53
76568-LED	20A	2.4kW	Standard	Yes	Dual	Incan.	53
76569	20A	2.4kW	Hi Rise	Yes	Dual	Incan.	53
76569-LED	20A	2.4kW	Hi Rise	Yes	Dual	Incan.	53
76570	20A	2.4kW	Constant	Yes	Dual	Incan.	59
76571	20A	2.4kW	Nondim	Yes	Dual	Incan.	56
76571-LED	20A	2.4kW	Nondim	Yes	Dual	Incan.	56
76572	20A	2.4kW	Sinewave	Yes	Dual	Incan.	62
76573	20A	2.4kW	Basic	No	Quad	Incan.	54
76574	50A	6.0kW	Basic	No	Single	Incan.	83
76575	50A	6.0kW	Standard	No	Single	Incan.	83

Catalog #	Ampacity	Kw	Type	Reporting	Number of Chans	Load	Module Type
76576	50A	6.0kW	Hi Rise	No	Single	Incan.	83
76577	50A	6.0kW	Constant	No	Single	Incan.	85
76578	50A	6.0kW	Nondim	No	Single	Incan.	84
76579	50A	6.0kW	Basic	Yes	Single	Incan.	83
76579-LED	50A	6.0kW	Basic	Yes	Single	Incan.	83
76580	50A	6.0kW	Standard	Yes	Single	Incan.	83
76580-LED	50A	6.0kW	Standard	Yes	Single	Incan.	83
76581	50A	6.0kW	Hi Rise	Yes	Single	Incan.	83
76581-LED	50A	6.0kW	Hi Rise	Yes	Single	Incan.	83
76582	50A	6.0kW	Constant	Yes	Single	Incan.	85
76583	50A	6.0kW	Nondim	Yes	Single	Incan.	84
76583-LED	50A	6.0kW	Nondim	Yes	Single	Incan.	84
76584	100A	12.0kW	Constant	No	Single	Incan.	89
76585	100A	12.0kW	Basic	No	Single	Incan.	87
76586	100A	12.0kW	Constant	Yes	Single	Incan.	89
76586-LED	100A	12.0kW	Constant	Yes	Single	Incan.	89
76587	100A	12.0kW	Basic	Yes	Single	Incan.	87
76587-LED	100A	12.0kW	Basic	Yes	Single	Incan.	87
76588	Blank	N/A	N/A	No	N/A	N/A	17
76589	N/A	2.4kW	Test Mod.	No	Dual	Incan.	53
76590	N/A	2.4kW	Test Mod.	No	Quad	Incan.	54
76591-0001	20A	2.4kW	Dim/Nondim	No	Dual	Incan.	63
76591-0002	20A	2.4kW	Nondim/Dim	No	Dual	Incan.	65
76591-0003	10A	1.2kW	Nondim	No	Quad	Incan.	23
76591-0004	15A	1.8kW	Nondim	No	Quad	Incan.	23
76591-0005	20A	2.4kW	Nondim	No	Quad	Incan.	23
76591-0006	15A	1.8kW	Basic	No	Quad	Incan.	37

230V Dimmer Modules The following dimmer & non-dim modules are currently available for the 230V markets:

Catalog #	Ampacity	Kw	Type	Reporting	Number of Chans	Load	Module Type
76600	13A	2.5kW	Basic	No	Quad	Tungsten	2
76601	16A	3.0kW	Standard	No	Dual	Tungsten	91
76602	16A	3.0kW	Standard	No	Dual	Tungsten	91
76603	16A	3.0kW	Standard	No	Dual	Tungsten	91
76604	16A	3.0kW	Hi-Rise	No	Dual	Tungsten	91
76605	16A	3.0kW	Hi-Rise	No	Dual	Tungsten	91
76606	16A	3.0kW	Hi-Rise	No	Dual	Tungsten	91
76607	16A	3.0kW	Standard	Yes	Dual	Tungsten	91
76607-LED	16A	3.0kW	Standard	Yes	Dual	Tungsten	91
76608	16A	3.0kW	Standard	Yes	Dual	Tungsten	91
76608-LED	16A	3.0kW	Standard	Yes	Dual	Tungsten	91
76609	16A	3.0kW	Standard	Yes	Dual	Tungsten	91
76610	16A	3.0kW	Hi-Rise	Yes	Dual	Tungsten	91
76610-LED	16A	3.0kW	Hi-Rise	Yes	Dual	Tungsten	91
76611	16A	3.0kW	Hi-Rise	Yes	Dual	Tungsten	91
76611-LED	16A	3.0kW	Hi-Rise	Yes	Dual	Tungsten	91
76612	16A	3.0kW	Hi-Rise	Yes	Dual	Tungsten	91
76613	25A	5.0kW	Standard	No	Dual	Tungsten	70
76614	25A	5.0kW	Standard	No	Dual	Tungsten	70
76615	25A	5.0kW	Standard	No	Dual	Tungsten	70
76616	25A	5.0kW	Hi-Rise	No	Dual	Tungsten	70
76617	25A	5.0kW	Hi-Rise	No	Dual	Tungsten	70
76618	25A	5.0kW	Hi-Rise	No	Dual	Tungsten	70
76619	25A	5.0kW	Standard	Yes	Dual	Tungsten	70
76619-LED	25A	5.0kW	Standard	Yes	Dual	Tungsten	70
76620	25A	5.0kW	Standard	Yes	Dual	Tungsten	70
76620-LED	25A	5.0kW	Standard	Yes	Dual	Tungsten	70
76621	25A	5.0kW	Standard	Yes	Dual	Tungsten	70
76622	25A	5.0kW	Hi-Rise	Yes	Dual	Tungsten	70
76622-LED	25A	5.0kW	Hi-Rise	Yes	Dual	Tungsten	70
76623	25A	5.0kW	Hi-Rise	Yes	Dual	Tungsten	70
76623-LED	25A	5.0kW	Hi-Rise	Yes	Dual	Tungsten	70
76624	25A	5.0kW	Hi-Rise	Yes	Dual	Tungsten	70
76625	50A	10.0kW	Standard	No	Single	Tungsten	83
76626	50A	10.0kW	Standard	No	Single	Tungsten	83
76627	50A	10.0kW	Standard	No	Single	Tungsten	83
76628	50A	10.0kW	Hi-Rise	No	Single	Tungsten	83
76629	50A	10.0kW	Hi-Rise	No	Single	Tungsten	83
76630	50A	10.0kW	Hi-Rise	No	Single	Tungsten	83
76631	50A	10.0kW	Standard	Yes	Single	Tungsten	83

Catalog #	Ampacity	Kw	Type	Reporting	Number of Chans	Load	Module Type
76631-LED	50A	10.0kW	Standard	Yes	Single	Tungsten	83
76632	50A	10.0kW	Standard	Yes	Single	Tungsten	83
76632-LED	50A	10.0kW	Standard	Yes	Single	Tungsten	83
76633	50A	10.0kW	Standard	Yes	Single	Tungsten	83
76634	50A	10.0kW	Hi-Rise	Yes	Single	Tungsten	83
76634-LED	50A	10.0kW	Hi-Rise	Yes	Single	Tungsten	83
76635	50A	10.0kW	Hi-Rise	Yes	Single	Tungsten	83
76635-LED	50A	10.0kW	Hi-Rise	Yes	Single	Tungsten	83
76636	50A	10.0kW	Hi-Rise	Yes	Single	Tungsten	83
76637	16A	3.0kW	Sinewave	Yes	Dual	Tungsten	100
76638	16A	3.0kW	Sinewave	Yes	Dual	Tungsten	100
76639	16A	3.0kW	Sinewave	Yes	Dual	Tungsten	100
76640	25A	5.0kW	Sinewave	Yes	Dual	Tungsten	76
76641	25A	5.0kW	Sinewave	Yes	Dual	Tungsten	76
76642	25A	5.0kW	Sinewave	Yes	Dual	Tungsten	76
76643	16A	3.0kW	Fluor	No	Single	Flour	106
76644	16A	3.0kW	Fluor	No	Single	Flour	106
76645	16A	3.0kW	Fluor	No	Single	Flour	106
76646	16A	3.0kW	Nondim	No	Dual	Tungsten	94
76647	16A	3.0kW	Nondim	No	Dual	Tungsten	94
76648	16A	3.0kW	Nondim	No	Dual	Tungsten	94
76649	16A	3.0kW	Nondim	Yes	Dual	Tungsten	94
76649-LED	16A	3.0kW	Nondim	Yes	Dual	Tungsten	94
76650	16A	3.0kW	Nondim	Yes	Dual	Tungsten	94
76650-LED	16A	3.0kW	Nondim	Yes	Dual	Tungsten	94
76651	16A	3.0kW	Nondim	Yes	Dual	Tungsten	94
76652	25A	5.0kW	Nondim	No	Dual	Tungsten	72
76653	25A	5.0kW	Nondim	No	Dual	Tungsten	72
76654	25A	5.0kW	Nondim	No	Dual	Tungsten	72
76655	25A	5.0kW	Nondim	Yes	Dual	Tungsten	72
76655-LED	25A	5.0kW	Nondim	Yes	Dual	Tungsten	72
76656	25A	5.0kW	Nondim	Yes	Dual	Tungsten	72
76656-LED	25A	5.0kW	Nondim	Yes	Dual	Tungsten	72
76657	25A	5.0kW	Nondim	Yes	Dual	Tungsten	72
76658	16A	3.0kW	Constant	No	Dual	Tungsten	97
76659	16A	3.0kW	Constant	No	Dual	Tungsten	97
76660	16A	3.0kW	Constant	No	Dual	Tungsten	97
76661	16A	3.0kW	Constant	Yes	Dual	Tungsten	97
76662	16A	3.0kW	Constant	Yes	Dual	Tungsten	97
76663	16A	3.0kW	Constant	Yes	Dual	Tungsten	97
76664	25A	5.0kW	Constant	No	Dual	Tungsten	74
76665	25A	5.0kW	Constant	No	Dual	Tungsten	74
76666	25A	5.0kW	Constant	No	Dual	Tungsten	74

Catalog #	Ampacity	Kw	Type	Reporting	Number of Chans	Load	Module Type
76667	25A	5.0kW	Constant	Yes	Dual	Tungsten	74
76668	25A	5.0kW	Constant	Yes	Dual	Tungsten	74
76669	25A	5.0kW	Constant	Yes	Dual	Tungsten	74
76670	16A	3.0kW	Test Mod	No	Dual	Tungsten	91
76671	16A	3.0kW	Test Mod	No	Dual	Tungsten	91
76672	16A	3.0kW	Test Mod	No	Dual	Tungsten	91
76673-0001	20A	4.0kW	Hi-Rise	Yes	Dual	Tungsten	53
76673-0002	20A	4.0kW	Nondim	Yes	Dual	Tungsten	56
76673-0003	13A	2.5kW	Nondim	No	Quad	Tungsten	23
76673-0004	16A	3.0kW	Fluor	Yes	Single	Flour	106
76673-0005	16A	3.0kW	Fluor	Yes	Single	Flour	106
76673-0006	16A	3.0kW	Fluor	Yes	Single	Flour	106

Rack Components

The C21/EC21 dimmer rack is a listed, free standing, factory assembly of welded steel and aluminum construction finished in a fine textured, scratch resistant coating.

Each C21/EC21 dimmer rack consists of a rack processor housing (RPH) with one or two rack processor modules (RPM), a fan module, and up to 24, 36 or 48 dimmer modules. The dimmer connectors at the back of the rack provide for load wire connection. Main bus bars are provided for line wire connections. An earth ground lug is provided in the rack. The dimmer connectors in the rack are polarized to prevent dimmer modules being plugged into the different ampacity slots. The dimmer racks can be individually fed or bused together using an optional busing kit.

Large dimmer racks have provision for up to 48 dimmer modules. Mid-range dimmer racks have provision for up to 36 dimmer modules. Small dimmer racks have provisions for up to 24 dimmer modules. Dimmer modules contain one, two or four dimmers, and dimmer module types can be mixed within a rack in various combinations.

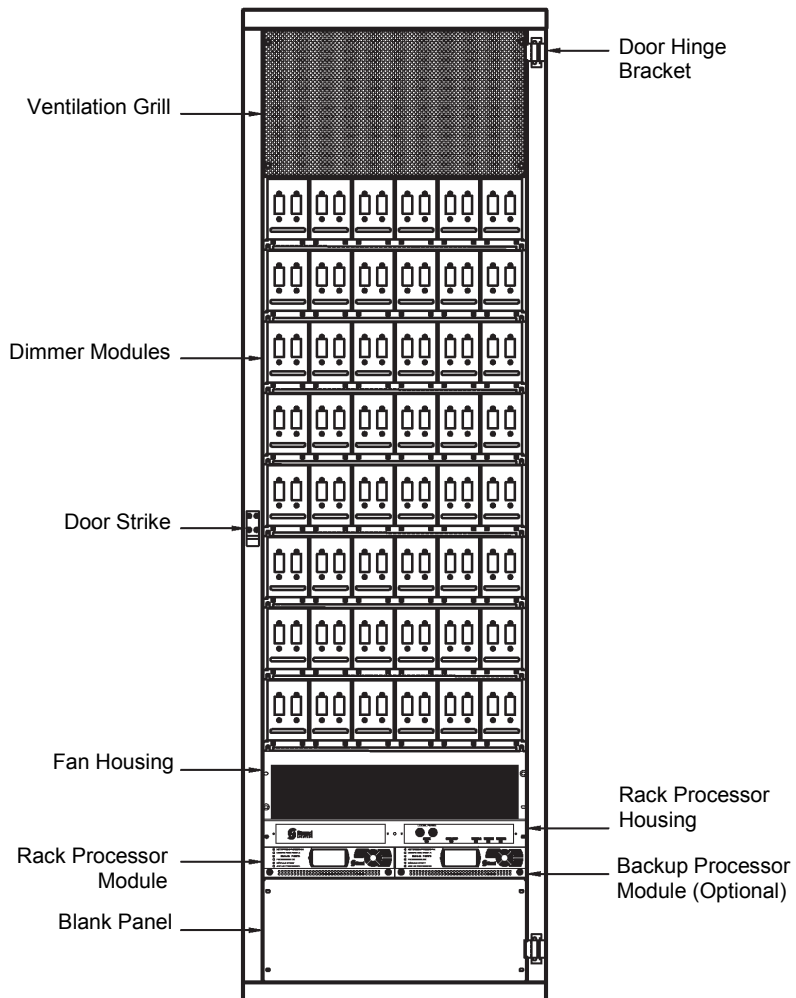

Figure 1 – C21/EC21 Series Dimmer Rack Fully Populated (doors removed)

Dimmer Modules

The power modules are the high power switching section of the C21/EC21 dimming system. The power block in this module is the interface between the high power AC and low power control. It is driven by low level signals (5mA, 3-24V) and switches high level signals (up to 100A, 120/240VAC). High specification filtering, SCR dimming, contactor non-dims, Sinewave dimming, and load status reporting electronics are available as options. Dimmers can be mixed in any combination in a rack. This lets you use the exact dimmer type needed for each circuit.

Quad dimming modules are also available in custom racks.

Power modules are constructed from aluminum, folded to form three sides of the dimmer and to support the dimmer connector and heatsink. The fourth side of the dimmer is formed by the heatsink. The top and bottom of the dimmer are open for cooling.

A sturdy handle is provided below the circuit breakers.

An optional mechanical locking bar on the dimmer tray secures the dimmers in the rack.

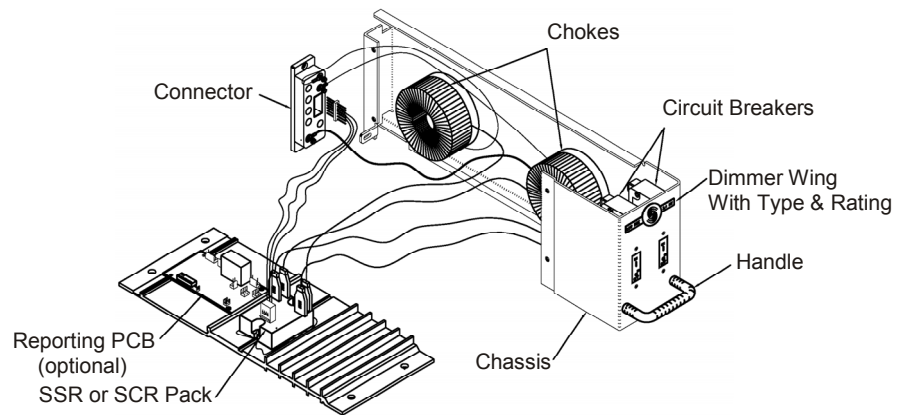

Figure 2 – Dual Dimmer Module

Reporting Dimmer Modules

Most C21/EC21 dimmer modules are available in load status reporting versions. Load status reporting versions of dimmers can be mixed in any combination with standard dimmers in C21/EC21 racks. These dimmers report many dimmer status items back to the processor. The information can be accessed through various menu items. The processor can then display a wide range of faults and diagnostic data.

Each Reporting dimmer module contains a temperature sensor which will shut it down if it overheats. Anything causing overheating in the rack will cause a gradual shutdown as each Reporting dimmer module overheats.

Fan Module

The dimmer racks are cooled by a set of three low noise variable speed fans in a fan module at the bottom of the rack. The cooling system is designed to let the rack continue functioning if any one of the three fans fail. Cooling air is pushed up through the dimmer stack and exhausted through venting at the top of the rack. These fans are for dimmer cooling only, and can be set to fixed or variable speeds.

The fixed speed fan setting is for situations where changes in ambient noise are a problem. With this setting, the fans are always ON when the dimmer rack is in operation.

The variable speed fan setting minimizes noise and maximizes fan life. With this setting, the fan speed is adjusted so that fans reach full when 24 dimmers are at full, or equivalent (e.g., 48 dimmers at 50%). Increases in fan speed take 1 minute with this setting, while decreases in fan speed take 5 minutes. Fans are turned OFF when no dimmers are in use.

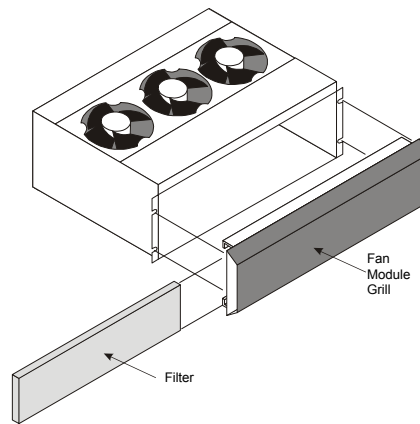

Figure 3 – Fan Housing

Rack Processor Housing

Each C21/EC21 dimmer rack contains a rack processor housing (RPH) with all of the control electronics for the rack. This RPH contains the processor module(s) (RPM), control station power supplies, and control interconnection card (CIC) for the rack, and is shipped separately from the rack to minimize the possibility of damage.

This chassis can be equipped with one or two processor modules. The second processor module acts as a backup. The configuration data from either processor can be transferred into the other processor. The currently inactive processor always tracks the currently active processor.

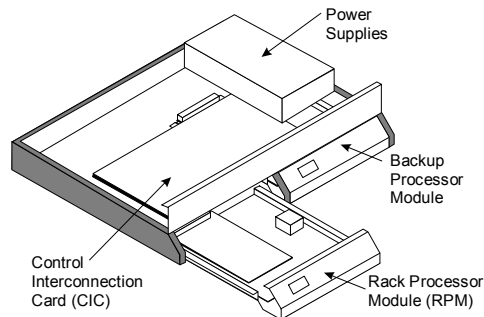



Figure 4 – Rack Processor Housing

Rack Processor Module

Each C21/EC21 rack contains one or two rack processor modules (RPM). Each processor module has a backlit LCD display, a 7 key keypad, and 6 LEDs to report processor module and dimmer status and allow setup and control at the rack. In normal operation, this display normally shows the rack name and the OK message. If there are any rack or dimmer events reported, the display will show error messages.

Pressing the  or  keys will take you into a series of setup menus to view and set up the more frequently used C21/EC21 features. See Section 3, *Processor Module Programming* for details on accessing these functions.

All programmed data is held in battery maintained RAM for up to 6 months without power.

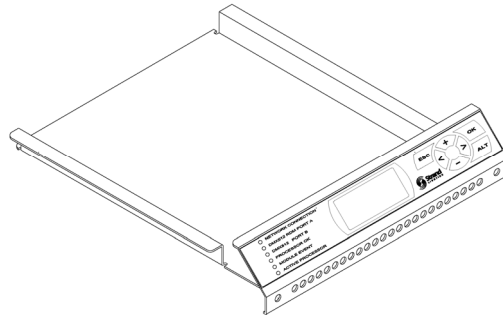

Figure 5 – Rack Processor Module

Power Supplies

Each C21/EC21 rack can have up to three power supplies, depending on the accessories provided. These power supplies are mounted on the rack processor housing.

Control Interconnection Card (CIC)

The electronics chassis also contains the control interconnection card (CIC). This is where the contractor terminates all control wiring for the rack. All control terminal strips are 2-part plug-in strips so that the electronics chassis can be easily removed from the rack.

Processor Configuration

Once you have applied power you need to make sure that the system is working correctly and the processor modules are set properly for the installation. This step checks for any problems due to shipping or installation.

Startup

When the rack is switched ON, a number of self-tests are run. The system displays the rack name.



When the self-tests are complete the PROCESSOR OK LED on the front of the processor module will turn ON, and the default text will show on the LCD display.

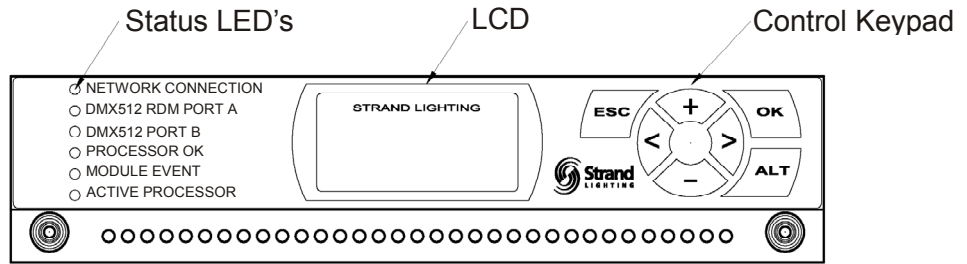

Figure 6 - Processor Module Front Panel

If the MODULE EVENT LED is ON, check the dimmer event log to see which dimmer is causing problems. If any other LED does not illuminate correctly, switch OFF the power immediately and check the installation again. If all wiring seems correct, call Strand Lighting or your local Authorized Service Center.

If the LCD display shows an error, see the Error Log section of chapter XX, Basic Troubleshooting.

LED Status

The LEDs on the front of each rack processor module are the first level of diagnostics and provide immediate visual status indication. The nine LEDs on the front of the rack processor housing and module indicate the following:

Rack Processor Housing LEDs

- Phase A (green): Should be ON if PhaseA/Line1 is OK.
- Phase B (green): Should be ON if Phase B/Line 2 is OK.
- Phase C (green): Should be ON if PhaseC/Line 3 is OK.
- Over-Temp (red): Should be OFF. Flashing indicates an Over-Temp condition. ON indicates dimmer module automatic Over-Temp shutdown.
- Panic (red): Should be OFF. On indicates that PANIC has Been activated.
- Lighthouse (blue): Blue = normal. Flashing red = error. Solid red = shutdown.

Rack Processor Module LEDs

- Network Connection (green): Should be ON if there is a network signal.
- DMX A (green): Should be ON if there is a DMX signal.
- DMX B (green): Should be ON if there is a DMX signal.
- Module Event (red): Should be OFF. On indicates a dimmer fault
- Processor OK (green): Should be ON. Off indicates there is a problem.
- Active Processor (green): Should be ON if self-test is OK. Indicates active processor.

Dimmer Events

If the Module Event LED is on, the LCD will show the number of dimmer events and will automatically scroll the display to show a description of the event(s). Refer to the appendices section of this manual for a description of event codes. If any other LED does not illuminate correctly, switch OFF the power immediately and check the installation again. If the fault persists and all wiring seems correct, call Strand Lighting or your local Authorized Service Center (www.strandlighting.com).

After Startup

1. Check the following items to make sure they are correctly set in the processor module:
 - Module type (see *Rack Config Menu* in section 3, *Front Panel Programming*)
 - Rack name (see *Rack Config Menu* in section 3, *Front Panel Programming*)
 - Starting multiplex signal number and dimmer protocol (see *Patching Menu* in section 3, *Front Panel Programming*)
 - Time and date (see *Rack Config Menu* in section 3, *Front Panel Programming*)

Other items you may wish to check at this time, depending on your system configuration, are:

- Mux patch (see *Patching Menu* in section 3, *Front Panel Programming*)
 - Outlook patch (see *Patching Menu* in section 3, *Front Panel Programming*)
 - Language (see *Rack Config Menu* in section 3, *Front Panel Programming*)
 - Max Voltage (see *Rack Config Menu* in section 3, *Front Panel Programming*)
 - Min Level (see *Rack Config Menu* in section 3, *Front Panel Programming*)
2. Switch on all load circuit breakers.
 3. Connect a suitable luminaire to each outlet and check every dimmer using the SET LEVEL control facility, a suitable control console, or an SWC hand held controller. Investigate and correct any malfunctions you find.

If any dimmers do not work, stop and check the slot type for the dimmer. Dimmers will not work properly if their slot type is incorrectly assigned. Make sure that all of the modules are in their correct slots, and that the slot type for each dimmer is correctly set in the processor module.
 5. Install the fan screens, door, to complete the system installation.

Section 2 - Operational Features

Rack Configuration The following configuration items are usually programmed during commissioning, but can also be reprogrammed by the user.

- Rack name.
- Panic selection and configuration
- Maximum output voltage (per dimmer): 20-250 volts (e.g. set to 105V for extended lamp life).
- Minimum level (per dimmer): 0% - 100% (e.g. set to 10% for aisle lights or large lamp preheat).
- Room and channel Patching (for applications using Outlook)
- Each dimmer can be patched to any valid DMX512 address number for the standard input A (DMX A), input B (DMX B) or network.
- Circuit ID—used by SWC and status reporting software.
- Record and recall presets (1-8, ON and OFF per room for Outlook control, and 0-128 per rack for System Wide Control).
- Define Preset Number or “Hold” condition on DMX failure.
- Define power-up preset per rack for Outlook architectural presets.
- Set LCD contrast.
- Error log accessible from the processor module or status reporting software.
- Individual dimmer reporting enable/disable.

Dimmer Configuration Configuration items associated with the dimmer module can be set from the processor module front panel.

- The output response profile can be set to Linear, Square, S-Curve, Fluo-Electric (for electronic fluorescent ballasts), Fluo-Magnetic (for magnetic fluorescent ballasts), and Non-Dim. The two fluorescent settings let you set the top end voltage and the bottom end cutoff voltage. The Non-Dim setting lets you set the turn-on threshold for the non-dim. Five additional user programmable profiles are available through the *Set Rack Configuration* menu or from the optional status reporting software.
- Dimmer response (per dimmer): fast (30ms), normal (100ms) or slow (300ms). This determines a dimmer’s rate of response to a change in control level. Slow is usually set for large tungsten loads to reduce filament inrush, medium or fast for small loads.
- Dimmer control assignment (per dimmer) to the “combined” levels of Outlook preset, SWC preset, DMX A, DMX B, Network or to a fixed level (0% - 99% or “Full”). The way in which the various input levels combine is also determined on a per dimmer basis by setting the dimmer DMX mode.
- A special smoothing algorithm is applied to small level changes to maintain smooth fades with long fade times.

Control Inputs The Control Interconnection Card, or CIC, is the printed circuit board on which all contractor control wiring connections are made. It is located on the top of the Rack Processor Housing (RPH) and contains:

- An optional Ethernet switch, which connects to a Strand ShowNet system and is Advanced Network Control (ACN) ready. This switch allows for easy connections between dimmer racks. It also connects to the network receptacle located in the upper left rear of the dimmer rack.
- Two optically isolated DMX512 control inputs. The first input will accept DMX512. The second DMX512 input is configurable to accept either DMX512, Strand Lighting's System Wide Control (SWC) dimmer protocol or Strand Lighting's Outlook architectural protocol. Each DMX input has a patch to allow overlapping or separation of any DMX control level.

- Six optically isolated contact inputs, for:

Pin	Function	Type	Description
1	PANIC ON	Momentary	Turns Panic On
2	PANIC OFF	Momentary	Turns Panic Off
3	FIRE ALARM	Maintained	Turns Panic On, No Override
4	SWC PRESET 1	Momentary	Fires SWC Preset 1
5	GO NEXT SWC	Momentary	Fires "Next" SWC Preset
6	GO SWC OFF	Momentary	Fires SWC Preset 0 (Blackout)
7	Com/Gnd		Com/Gnd
8	Com/Gnd		Com/Gnd

- An Audio Visual Interface port. This serial input will support connection to an external A/V or show control system that supports an RS232 serial connection.
- 96 or 192 panic select switches

Safety Features

In order to minimize the impact of failures to any part of C21/EC21 series dimmer racks, a number of security features, some of which are optional, are provided.

Standard safety features for C21/EC21 series dimmer racks are:

- Convection cooling of all components with fan assist.
- Three fans located at the bottom of the rack.
- Module over-temperature shutdown (Reporter modules only).
- The processor module can be set to hold the last dimmer levels forever, or to fade to a specified SWC preset after a preset interval in cases of DMX signal failure.
- Setup data is stored in non-volatile RAM.
- 2500V optical isolation of DMX A and DMX B inputs, SWC, Outlook communication.
- All, or selected dimmers in a rack can be set to either Off or full On when the external Panic button is pressed.
- Automatic Panic on removal of processor module. In racks with two processor modules, both modules must be removed to activate Panic.
- Keypad lock.

Optional safety features for C21/EC21 series dimmer racks include:

-
- Redundant tracking backup (requires a second processor module fitted to the rack). The backup processor automatically tracks the master processor and takes over control of the dimmer rack on failure of the master processor.
 - Status reporting software that lets you store setup data off-line.

System Wide Control (SWC)

SWC lets you control multiple C21/EC21 series dimmer racks from a single location. A hand held controller lets you program and recall all 128 presets, and control individual dimmers. 8 and 16 channel push-button stations let you record or recall any 8 or 16 of the 128 presets at each station. An audiovisual interface is also available to activate presets from external contacts. Contact Strand Lighting or see the *System Wide Control User's Manual* for details on how SWC works.

Outlook

Outlook is a comprehensive family of control stations designed for architectural applications needing a simple, flexible control solution with minimal installation and cabling costs. These control stations can access, modify, and recall lighting levels stored in the rack processor module. Outlook control station features and options include:

- Control up to 16 separate rooms, with up to 15 channels per room
- 8 preset scenes plus ON and OFF for each room
- Manual sliders (3, 6, 9, or 15 sliders per station) for direct control of individual circuits
- Record facility for saving slider levels for future push-button recall
- Programmable fade times between 0 and 4 minutes from Outlook control stations or 0 to 10 minutes from the processor module or status reporting software
- Record lockout facility for playback-only operation
- 1, 4, and 8 preset push-button stations
- Audio-visual interface
- Room combine stations for room partitioning

Section 3 - Programming the C21/EC21 Dimmer Rack

Controls and Displays You can access the range of C21/EC21 series dimmer rack programmable features using the Rack Processor Module keypad and 21 character, 8 line display. Menus are shown in English.

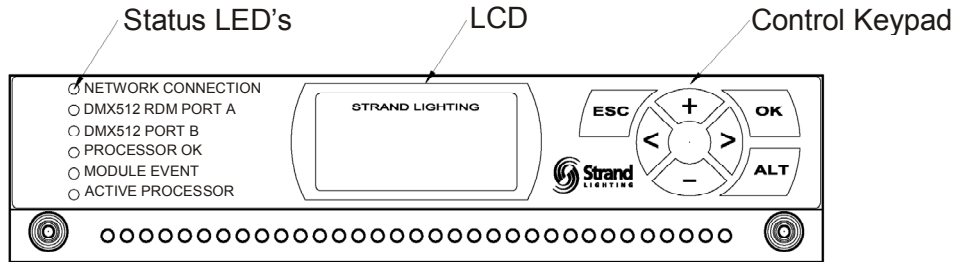



Figure 7 - Rack Processor Module Front Panel

The control buttons let you scan through the various menus and options and set the programmable features of the C21/EC21 series dimmer rack.



Key Lock To avoid accidental or unauthorized use of the keys, you can lock the keypad. When the Key Lock option is enabled, the processor keys are locked automatically after 10 minutes with no keyboard input. When disabled, the keys are unlocked. The factory default setting for this option is disabled. When locked, a key symbol is displayed on the lower-right side of the default display.

To temporarily unlock the keys

Press and hold  and  simultaneously for at least 2 seconds. Unless the Set Processor Key Lock option is disabled, the keys will again lock after 10 minutes of no key activity.

Using the Menu Keypad

The default display appears if no keys are pressed for 10 minutes, unless one or more error conditions have occurred. If more than one error has occurred, they are displayed continuously in sequence.

Press  or  to cycle through the status menu, which shows a summary of the main rack statistics.

In general the rack processor keys do the following:



Moves to the next menu or moves the cursor to the next digit of a field.



Moves to the next menu or moves the cursor to the next digit of a field.



Increases the value of a digit or field.



Decreases the value of a digit or field.



Selects a menu or sub-menu. It is also pressed to accept changes when fields are edited.



Returns the display to the previous menu level. Most configuration changes will not take effect until the escape button has been pressed.

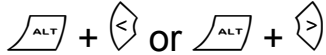

Selects a character group: numbers, capitol letters or lower-case letters.

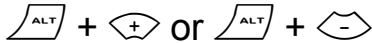

If the  keys are pressed while editing a text field, the text will return to the previous unedited text.

Note: The blank "space" symbol is located under the numbers character group.



Sets the maximum value for a field.

The Status Log

The Status Log lets you quickly check the status of the rack, using the  or  keys to display each parameter in turn.

If one or more error conditions occur, the status display automatically shows the Error Log, if a Dimmer Event occurs, the Event Log is automatically displayed, Multiple errors or events are auto-scrolled.

The Status log for each rack, lists the rack number and software version number, together with the error code and description of the error.



Note: When the backup and main processor are functioning, both displays should show "Tracking." When the system is properly tracking, data is continuously copied from the "Enabled" processor (Master) to the "Disabled" processor (Backup). Phase current will always be 0 (zero) on the backup processor.

The Status Log will return to the default display 5 seconds after the last key press.

The Main Menu

The main menu lets you access all the other menus for configuring C21/EC21 series dimmer racks.

To access the main menu

From any of the status displays, Press  or 

To return to the main menu

Press 

Note: If no dimmer event is registered, returning from the main menu brings you back to the display from which you called the main menu. If a dimmer event is registered you will return to the dimmer events display.

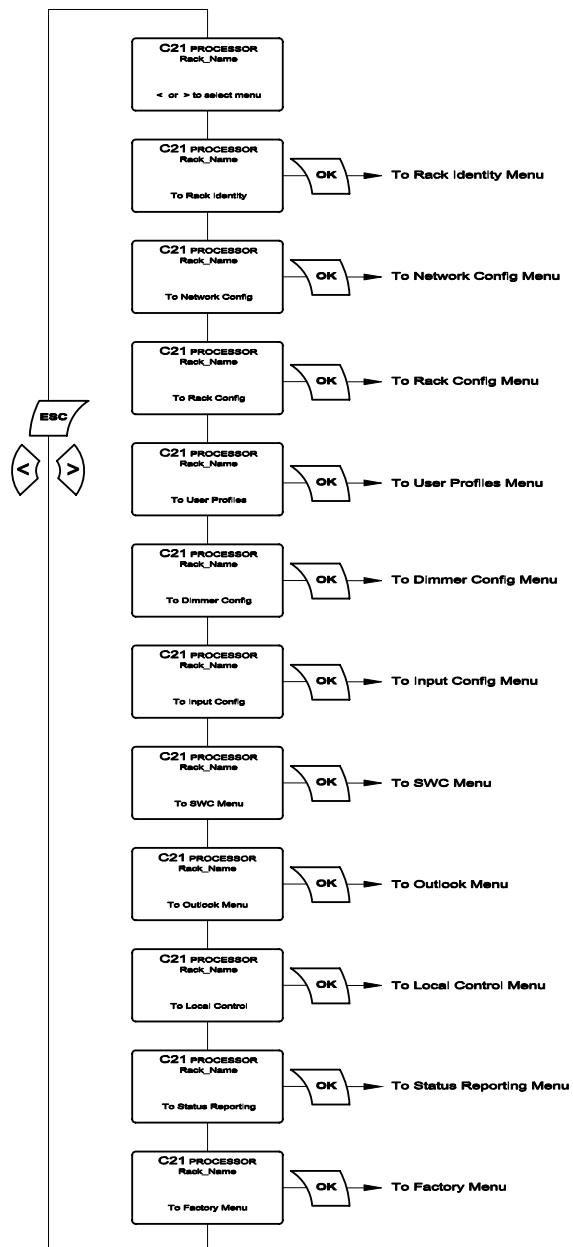

Rack Identity Menu

The Rack Identity menu allows you to configure the following settings for the dimmer rack:

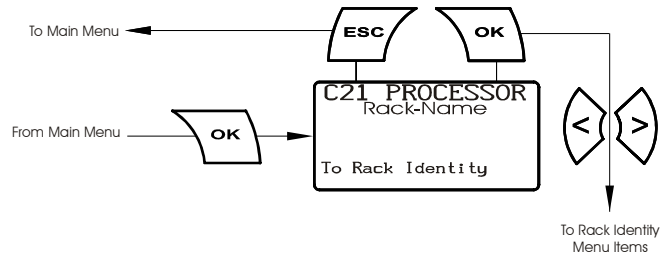

Set Rack Name

View or edit the name of the dimmer rack in this text field. The rack name is displayed on the second line of the display.

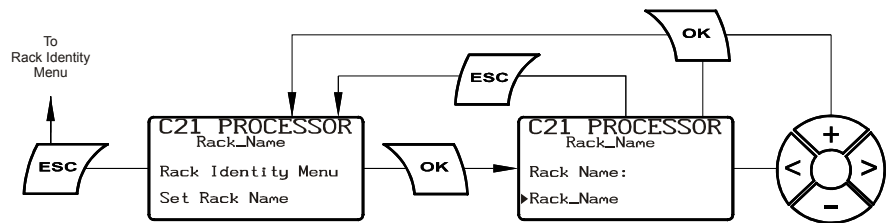

Set Rack Location

View or edit the location of the dimmer rack in this text field.

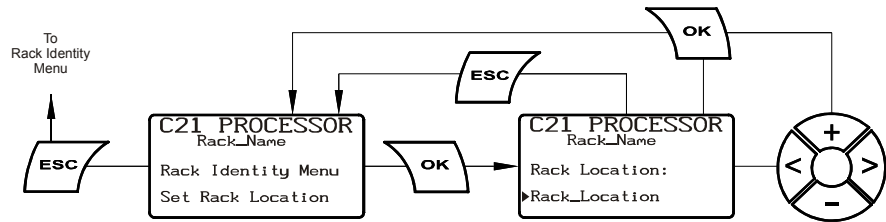

Set Main Breaker

View or edit the name or location of the main breaker in this text field.

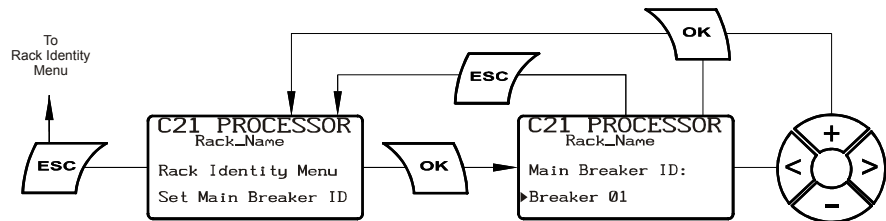

View Serial Number

Allows you to view the C21/EC21 Processor serial number. The serial number is entered by the factory and should not be changed in the field.

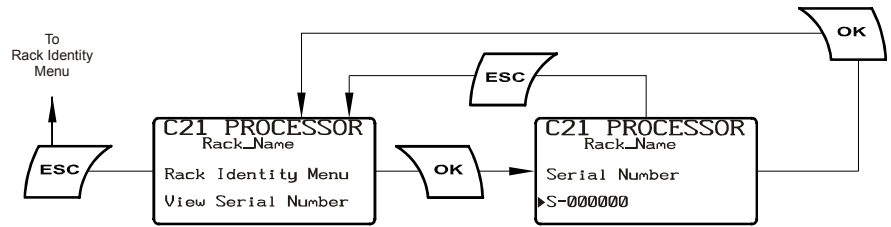

View Dealer Info.

Allows you to view the *Dealer Information* text field. The information for this text field is entered within the *Factory Menu* section.

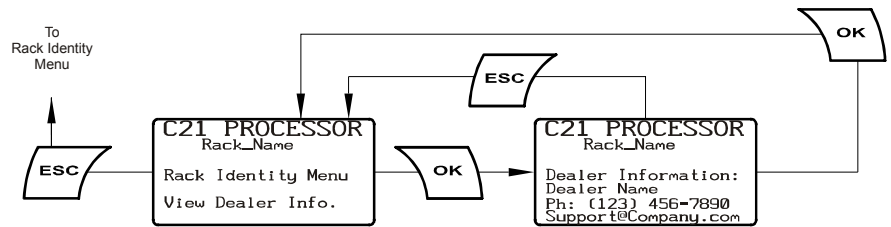

Set Date

Allows you to view or edit the date field.

Format: MM/DD/YY

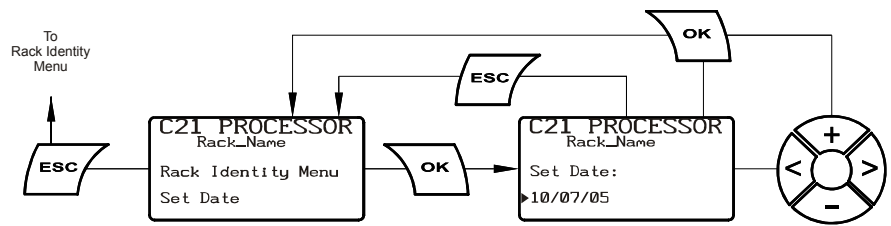

Set Time

Allows you to view or edit the time field.

Format: 24-hour (HH:MM:SS)

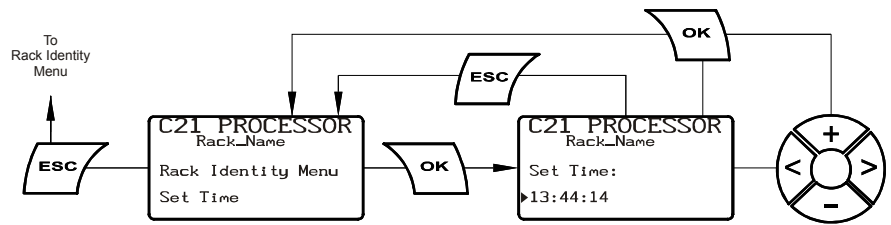

Set Temperature Scale

View or select the temperature scale

Options: Fahrenheit or Celsius

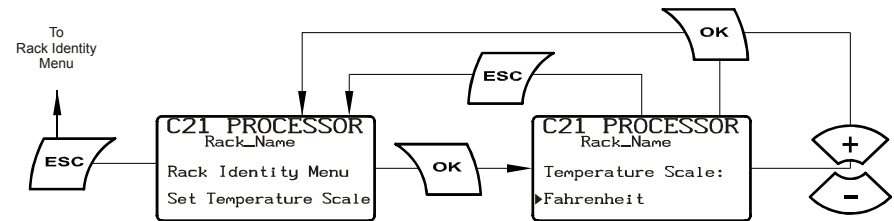

View Rack Size

Allows you to view the rack size (slot and dimmer count). The rack size is set in the *Factory Menu* section.

Default: 48 slot 96 Dims

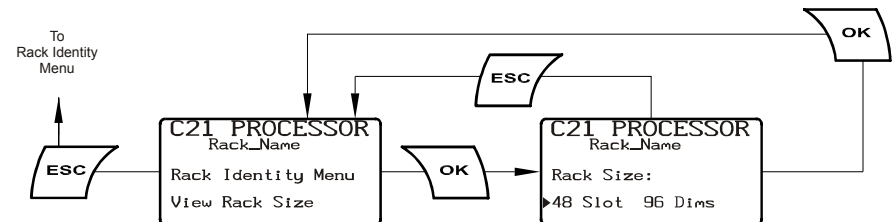

View Software Version

Allows you to view the current software version of the rack processor.

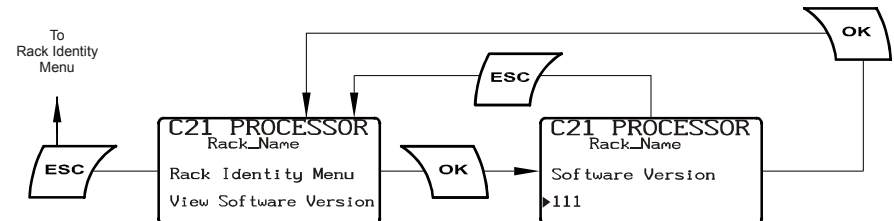

Network Config Menu

The Network Config menu allows you to configure the following settings for the network settings of the dimmer rack:

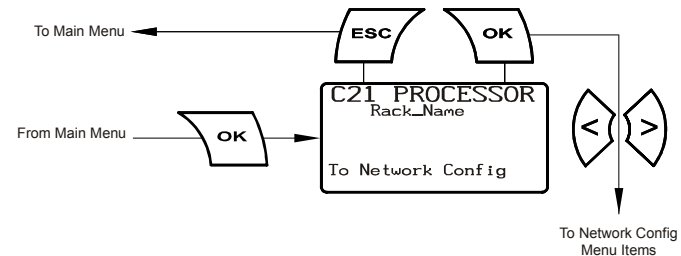

Set IP Address

Allows you to enter the IP address for the rack processor.

The default IP address is: 192.168.0.72

Note: Every rack processor is set to this default IP address. Make sure you create a unique number for each dimmer rack in the system prior to adding the racks to the network.

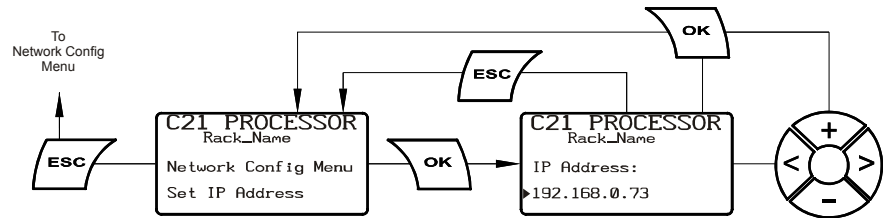

Set SubNet Mask

Allows you to set the SubNet Mask for the rack processor.

The default SubNet Mask is: 255.255.255.0.

Note: The default subnet Mask should not be changed unless instructed to do so by Strand Lighting.

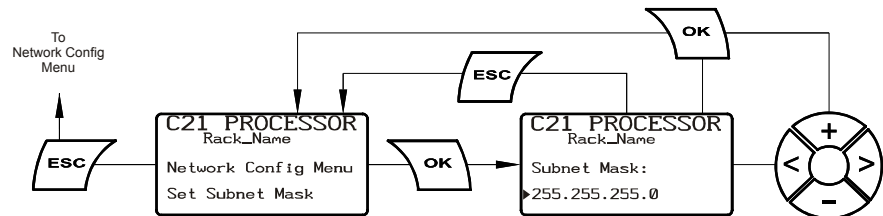

Set Host Name

Allows you to set the Host Name for the processor.

Enter a unique name for the rack processor in this text field.

Note: This field is node name seen on the network and is different than the dimmer rack name created in the Rack Identity Menu.

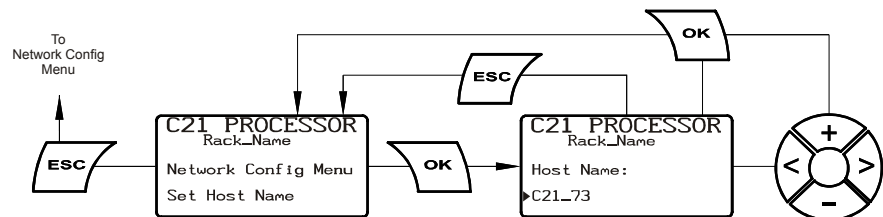

Set Gateway IP

Allows you to set the Gateway IP address for the processor.

The default Gateway IP is: 0.0.0.0

Note: The default Gateway IP address should not be changed unless instructed to do so by Strand Lighting.

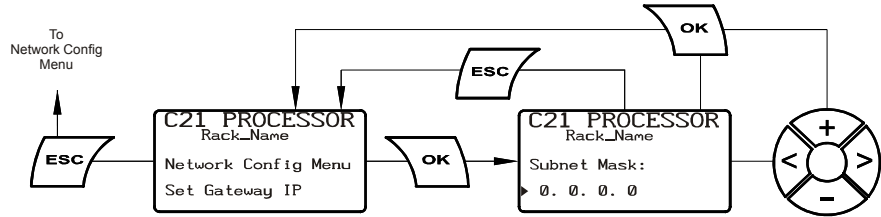

Rack Config menu

Rack Config Menu allows you to set the configuration of the dimmer rack.

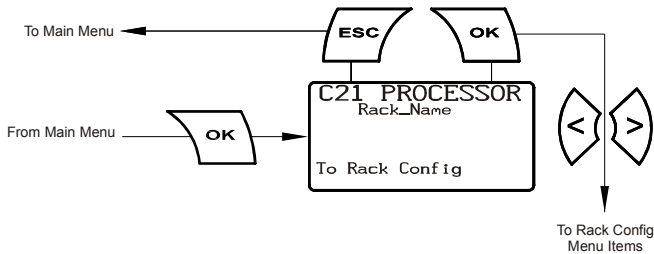

Review Module Types

Allows you to review the dimmer module type (00 through 99) assigned to the dimmer slots, 6 dimmers at a time.

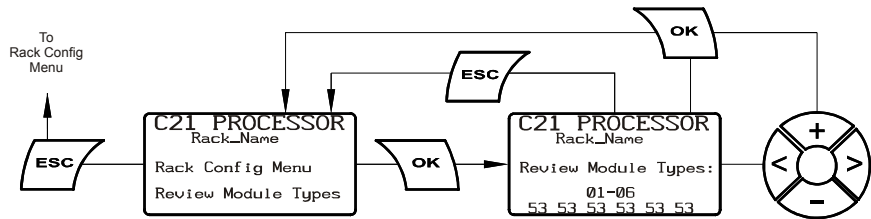

Set Module Type

Allows you to set a single dimmer module type (00 through 99) for each rack slot.

See Section 1 to view a list of the dimmer module types for the 120v and 230v markets.

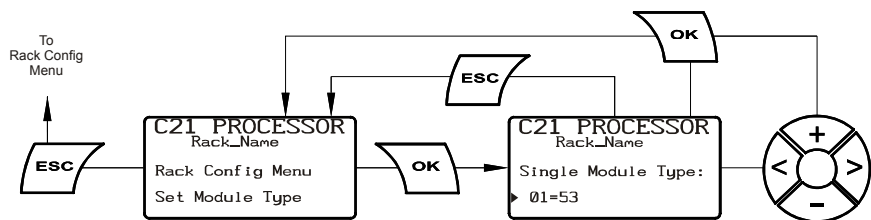

Set Module Type Range

Allows you to set the module type (00 through 99) for a range of dimmer rack slots.

See Section 1 to view a list of the dimmer module types for the 120v and 230v markets.

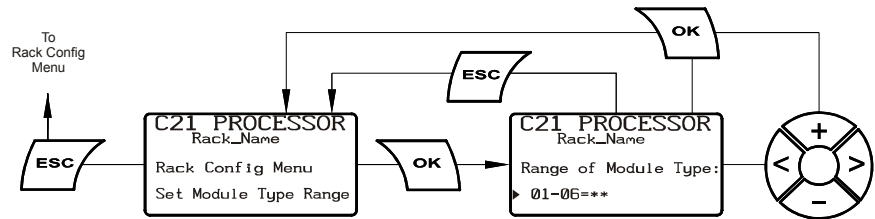

Set Fan Control

Allows you to view or edit the fan operation mode.

Fan operation modes are:

On Demand: Fans cool based on load

On Control: Fans cool based on signal

Continuous: Fans run at 100%

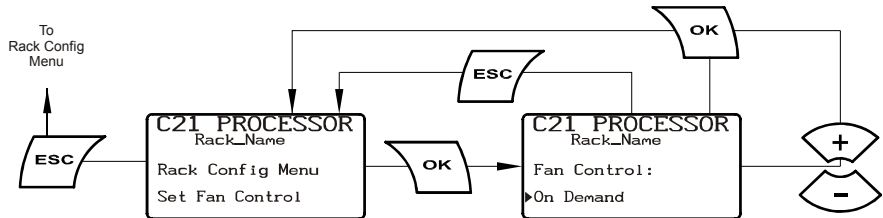

Set LCD Backlight

Allows you to view or edit the LCD backlight.

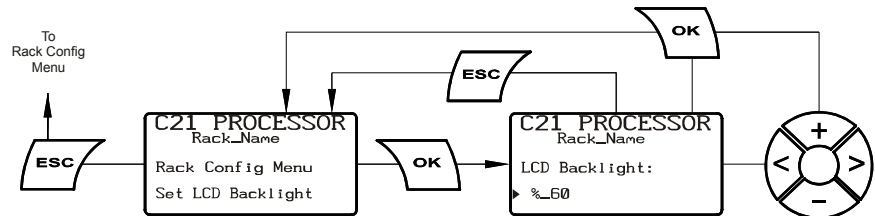

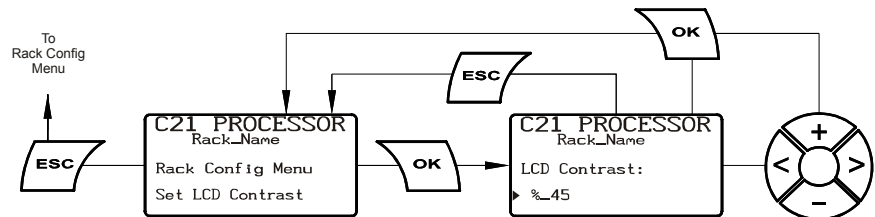

Set LCD Contrast

Allows you to view or edit the LCD Contrast.



Set Keypad Lock

Allows you to enable or disable to keypad lockout.

The C21 processor incorporates a safety system to lock out the processor keys to prevent tampering by unauthorized personnel. When the keys are locked, a key symbol is displayed on the right-hand side of the LCD on the default display only. Under this condition, the keys are inoperable unless you press the  and  keys simultaneously, and hold them for about two seconds to release the lock. When enabled, the key lock will automatically lock the keys if no keys are pressed for a period of ten minutes.

When disabled, the keys are always unlocked.

When set to enabled, keys are not locked and the key lock symbol is not displayed on the default display until ten minutes after the last key is pressed.

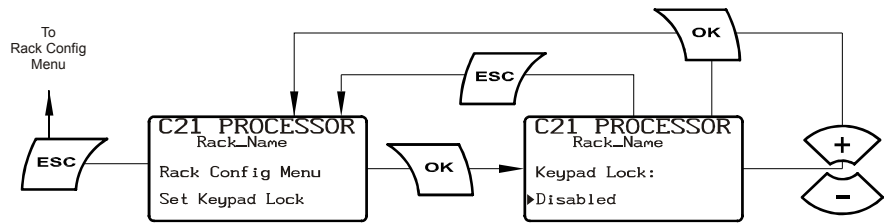

Set Active Processor

Allows you to select which processor, main or backup, will be active.

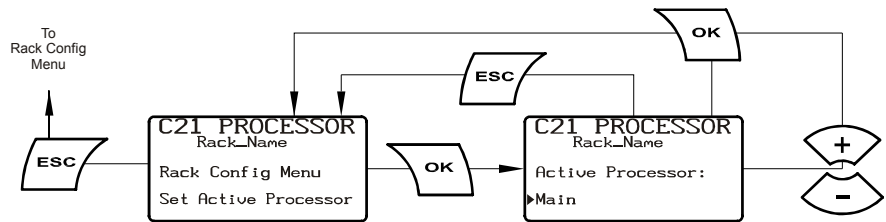

Save Recovery Config

Allows you to save the current processor configuration as a recovery file on the Control Interconnection Card (CIC) or to the flash RAM.

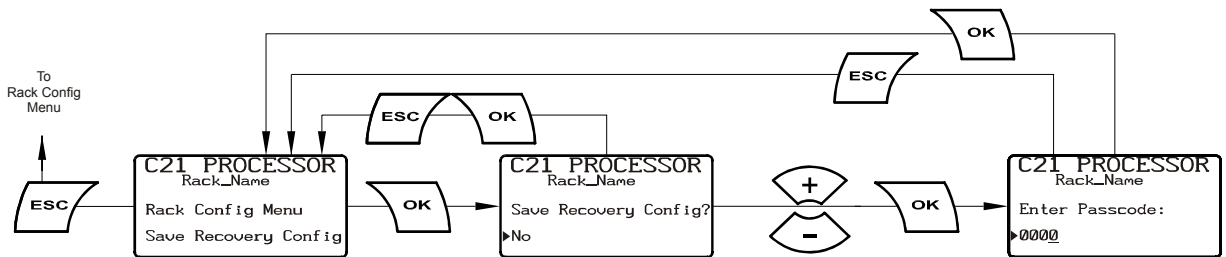

Restore Saved Config

Allows you to restore the saved configuration file from the Control Interconnection Card (CIC) or from the flash RAM .

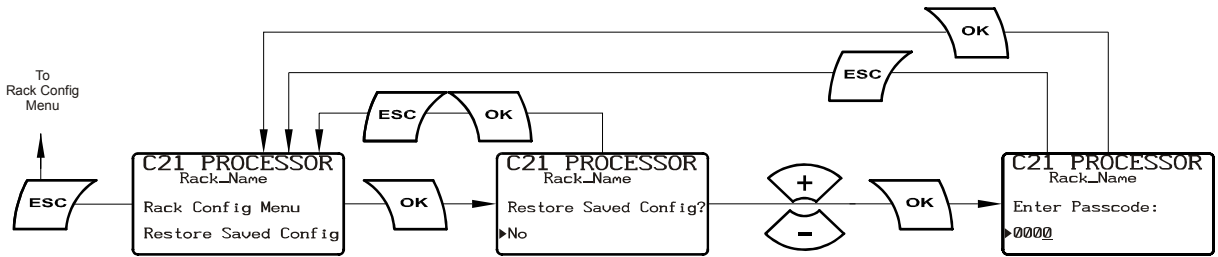

Change Pass Code

Allows you to create a 4-digit pass code for secured menu items.

Note: The Default pass code of '2606' is always enabled and cannot be changed.

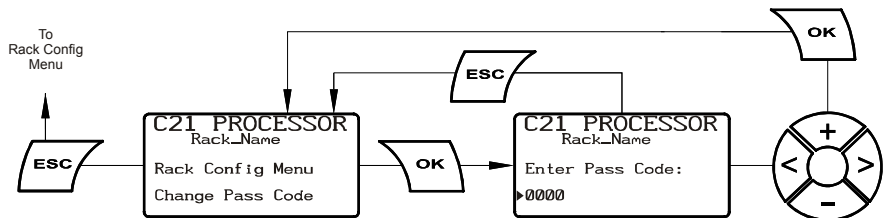

User Profile Menu

User Profile Menu allows you to view and create the five user-defined dimming curves.

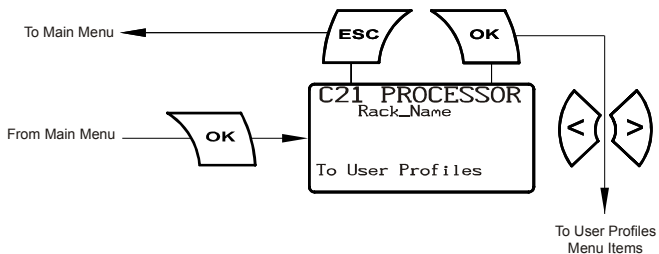

Set User Profile

Allows you to view or edit five user-defined dimmer profiles (dimming curves) that may be applied using the *Select Profiles* function under the *Dimmer Config menu*. You can set the input and output values for up to 100 steps for each user profile.

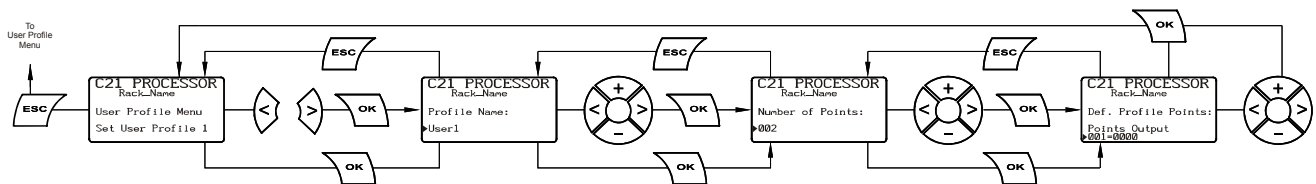

Dimmer Config Menu

Dimmer Config Menu allows you to set the configuration the dimmer modules and the priority of the discrete signals.

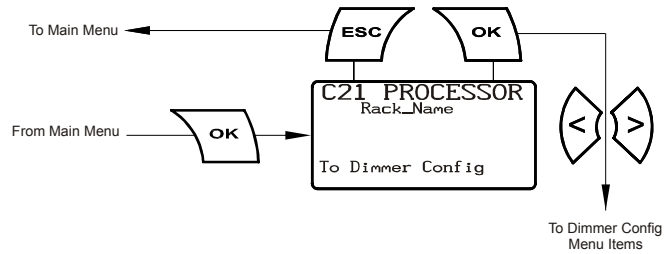

Set Dimmer Patch

Allows you to assign ranges of dimmers to listen to net-slots at various priority or HTP levels.

Note: Below are the four default patches.

	Dimmers	Nslot	Pri
001	001-192	00001	00h
002	001-192	01537	01h
003	001-192	02049	02h
004	001-192	19001	00
005	*****	*****	***

Column #1	Lists the number of the patch
Column #2 - Dimmers	Lists the range of dimmers assigned to the patch.
Column #3 - Nslot (Netslot)	Lists the start number of the range
Column #4 - Pri (Priority)	Lists the priority number and if it is assigned as HTP

Note: By default all 192 possible dimmers are assigned. Generally this number will reflect the actual number of dimmers in the rack.

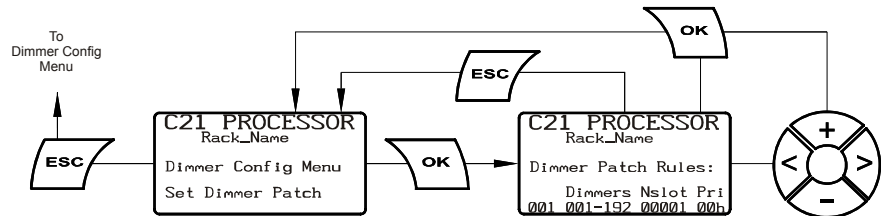

View Full Output V.

Allows you to view the Maximum output voltage of the dimmers, six at a time.

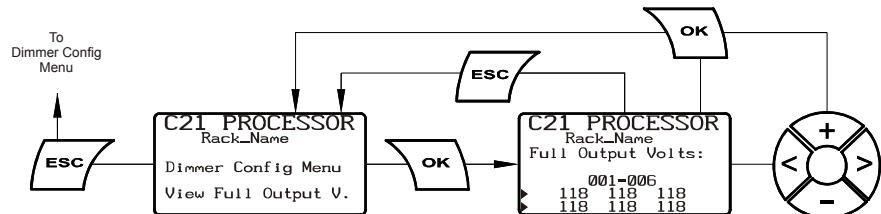

Set Full Output Volts

Allows you to set the Maximum output voltage for any range of dimmers in the rack. For instance, you can set the maximum voltage lower than the rated voltage of your lamps for improved lamp life. If you have lamps or other equipment which operate at a lower line voltage, you can set the output from the dimmer to an appropriate voltage for the devices.

The maximum output voltage is applied to all dimmers and dimmers assigned as non-dims. It is not applied to contactor non-dims. You cannot use contactor non-dims for devices which need a maximum output voltage setting.

Note: This function sets the dimmer output voltage, not the maximum control level applied to the dimmer.

Caution: Be careful when using a maximum output voltage with dimmers set for PANIC. When panic is activated, full output voltage appears at the output of any dimmer or non-dim set for PANIC, regardless of how the maximum output voltage is set.

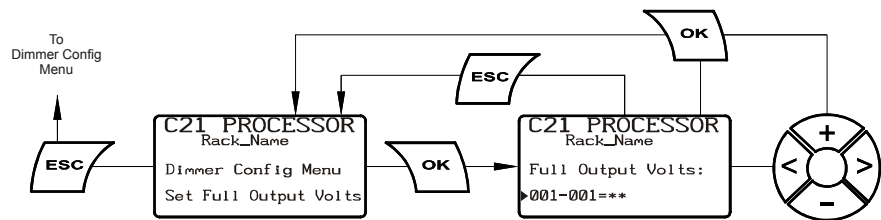

View Regulation Mode

Allows you to view the dimming curve assigned to a range of dimmers, 6 dimmers at a time.

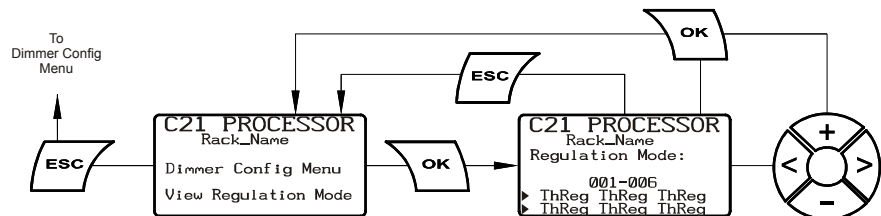

Set Regulation Mode

Allows you to set the Regulation Mode for a range of dimmers.

These options are:

SiUnr = SineWave dimmer unregulated

SiReg = SineWave dimmer regulated

N-Dim = Non-Dim

ThUnr = Thyristor dimmer unregulated

ThReg = Thyristor dimmer regulated

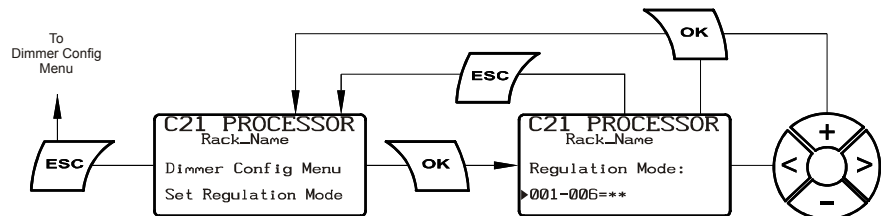

Set Response Times

The response time of a dimmer is the rate at which it responds to increases or decreases in the control level. C21/EC21 dimmer racks provide three response times:

Slow = 300ms
Medium = 100ms
Fast = 30ms

These options can be applied to a single dimmer or a range of dimmers. Slow is generally used for large lamp loads, while fast is used for smaller lamp loads that might be used in a chase effect.

Note: The 'fast' setting, together with the accuracy of digital dimmers can cause very high inrush currents to flow. These may damage large lamp filaments and cause circuit breakers to trip. Only set dimmers to 'fast' if necessary for a particular effect. Do not use 'fast' for lamps that are 5Kw or higher.

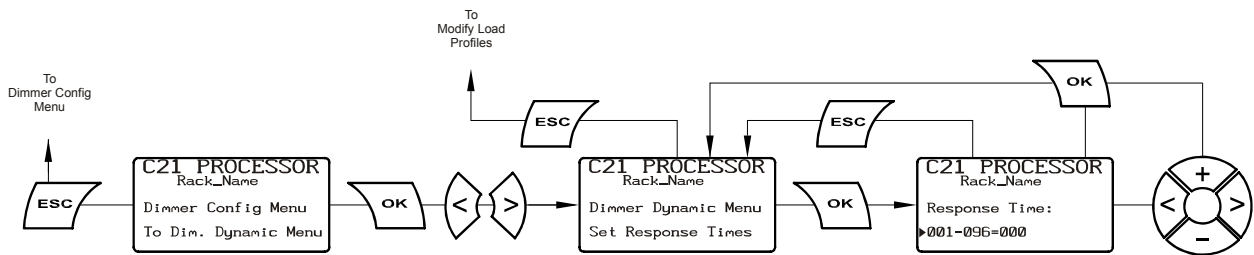

View Profiles

Allow you to view the dimming curve for the dimmers, six dimmers at a time.

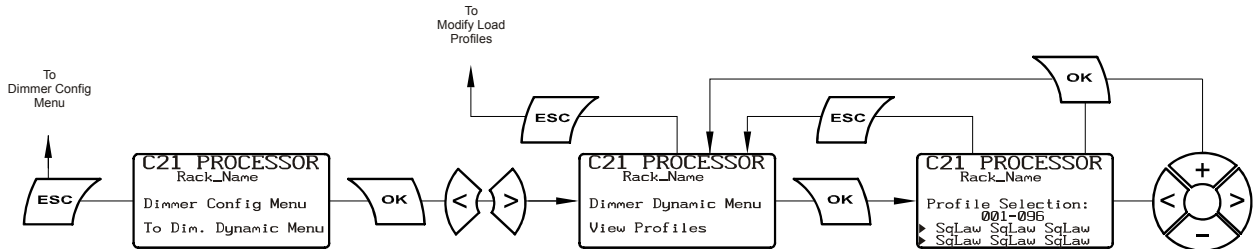

Select Profiles

Allows you to select the dimming curve for a range of dimmers:

SqLaw = Square Law
S-Crv = S-Curve
LinPw = Linear
N-Dim = Non-Dim
FIEle = Fluorescent Electronic
FIMag = Fluorescent Magnetic
MarkX = Advanced Mark X Ballasts
User1 = User Defined Dimming Curve #1
User2 = User Defined Dimming Curve #2
User3 = User Defined Dimming Curve #3
User4 = User Defined Dimming Curve #4
User5 = User Defined Dimming Curve #5

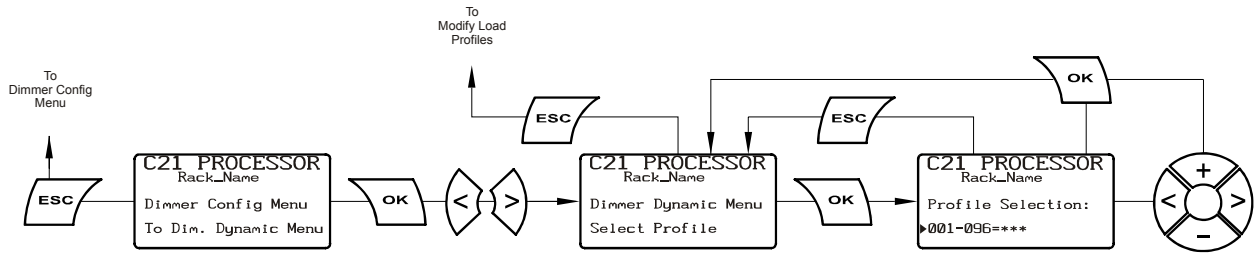

View Cut Levels View Cut Levels

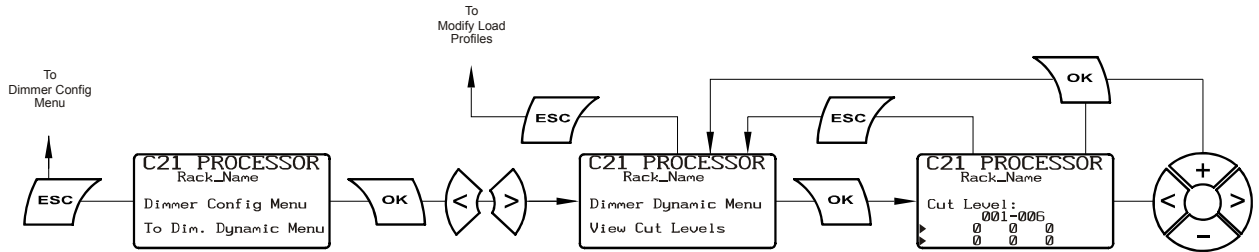

Set Cut Levels Set Cut Levels

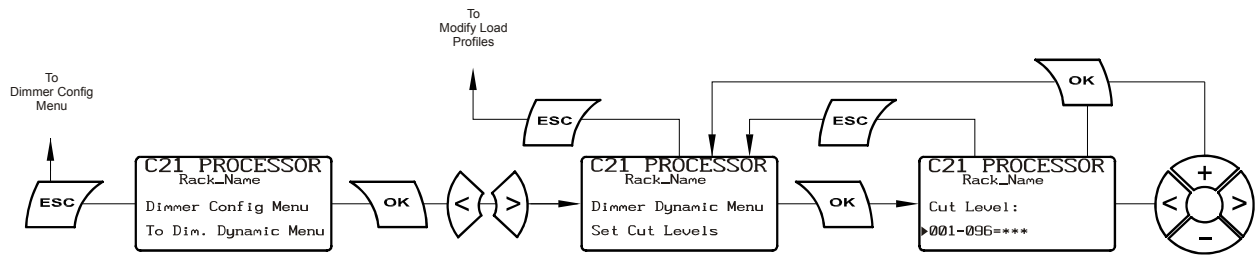

View Minimum Levels Allows you to view the minimum dimmer output level, 6 dimmers at a time.

